



SAFETY AND OPERATING INSTRUCTIONS



Please read through these Safety & Operating Instructions and the Engine Manufacturer's Owner's Manual to become familiar with the basic features of the *EASY AUGER* before operating it.

MACKISSIC, INC. P.O. BOX 111, PARKER FORD, PA 19457
PHONE: (610) 495-7181 e-mail: info@mackissic.com FAX: (610) 495-5951
www.mackissic.com

P/N 850-0001
06/28/11

SECTION I - SAFETY



This symbol points out important safety instructions, which, if not followed, could endanger the personal safety and/or property of yourself and others. Read and follow all instructions in this manual before attempting to operate your easy Auger. Failure to comply with these instructions may result in personal injury. When you see this symbol - **heed its warning**.

THIS MACHINE IS CAPABLE OF INFLICTING SERIOUS INJURY IF OPERATED IMPROPERLY -- READ WARNINGS & CAUTION LABELS.

INTENDED USE

NEVER USE YOUR EASY AUGER FOR ANY PURPOSE OTHER THAN DIGGING HOLES. IT IS DESIGNED FOR THIS USE AND ANY OTHER USE MAY CAUSE SERIOUS INJURY.



DANGER: MOVING PARTS CAN CRUSH AND CUT. KEEP HANDS CLEAR.



DANGER: YOUR EASY AUGER WAS BUILT TO BE OPERATED ACCORDING TO THE RULES FOR SAFE OPERATION IN THIS MANUAL. **AS WITH ANY TYPE OF POWER EQUIPMENT, CARELESSNESS OR ERROR ON THE PART OF THE OPERATOR CAN RESULT IN SERIOUS INJURY.** IF YOU VIOLATE ANY OF THESE RULES, YOU MAY CAUSE SERIOUS INJURY TO YOURSELF OR OTHERS.



WARNING: THE ENGINE EXHAUST FROM THIS PRODUCT CONTAINS CHEMICALS KNOWN TO THE STATE OF CALIFORNIA TO CAUSE CANCER, BIRTH DEFECTS OR OTHER REPRODUCTIVE HARM.



FAILURE TO COMPLY WITH THE PRECAUTIONS AND INSTRUCTIONS PROVIDED WITH THIS EASY AUGER CAN RESULT IN SERIOUS BODILY INJURY.



DO NOT ATTEMPT TO MOVE, TRANSPORT, OR OPERATE THIS MACHINE UNTIL ALL INSTRUCTIONS, WARNINGS, AND PRECAUTIONS ARE UNDERSTOOD.



ONLY PERSONS WHO CAN UNDERSTAND AND FOLLOW THE INSTRUCTIONS IN THIS MANUAL SHALL OPERATE THE EASY AUGER.

CHECK ALL FLUIDS BEFORE OPERATING THIS EASY AUGER. THE ENGINE AND THE HYDRAULIC SYSTEM HAVE BEEN SHIPPED WITHOUT FLUIDS AND OPERATING THE MACHINE WITHOUT SERVICING THEM WILL CAUSE DAMAGE!

MAKE CERTAIN THAT ALL SAFETY LABELS ON THIS EQUIPMENT ARE KEPT CLEAN AND IN GOOD CONDITION. IF YOU NEED REPLACEMENT LABELS, PLEASE ORDER PART NUMBER 850-5023. ALL OF THE FOLLOWING DECALS COME ON ONE SHEET.

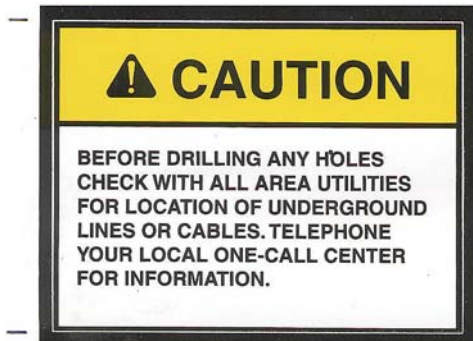

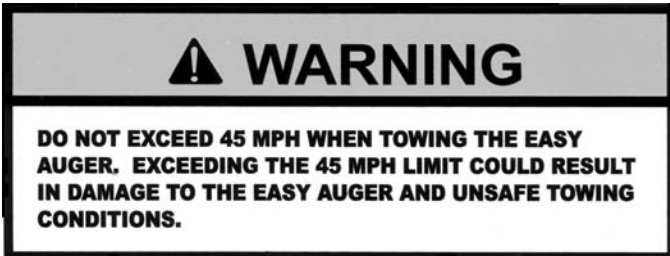

THESE SAFETY DECALS ALL COME ON ONE SHEET. WHEN ORDERING, USE PART NUMBER 850-5023.

THIS MACHINE HAS BEEN SHIPPED WITHOUT FLUIDS. BE SURE TO SERVICE THE UNIT ACCORDING TO ALL DIRECTIONS BEFORE USE.

GENERAL SPECIFICATIONS

PUSH UNITS

Length: 105" (266.7 cm)
Width: 30" (76.2 cm)
Height: 33" (83.8 cm) with drill frame parallel to the ground.
Weight: 360 lbs. (163.3 kg)
Engine: 9 HP Honda or
9 HP Robin

Capacities:

Hydraulic Tank - 8.5 Qts (8.04L)

Fuel Tank Honda 1.59 Gal
B&S 4 Qts

SELF PROPELLED UNITS

Length: 103" (261.7cm)
Width: 34" (86.4 cm)
Height: 33" (83.8 cm) with drill frame parallel to the ground.
Weight: 410 lbs. (190.5 kg)
Engine: 9 HP Honda or
9 HP Robin

Capacities:

Hydraulic Tank - 8.5 Qts (8.04L)

Fuel Tank Honda 1.59 Gal
B&S 4 Qts

SECTION II - ASSEMBLY

- THE MACKISSIC EASY AUGER HAS BEEN SHIPPED PARTIALLY DISASSEMBLED FOR ECONOMY OF SHIPMENT. THE UNIT WILL REQUIRE SOME ASSEMBLY AND ADJUSTMENT BEFORE IT CAN BE USED.
- THE MACHINE HAS BEEN SHIPPED WITHOUT ANY FLUIDS IN THE HYDRAULIC SYSTEM OR THE ENGINE. DO NOT ATTEMPT TO START THE ENGINE WITHOUT FIRST ADDING FLUIDS TO BOTH SYSTEMS.
- STARTING THE MACHINE WITHOUT ADDING OIL TO THE ENGINE OR HYDRAULIC FLUID TO THE EASY AUGER WILL IMMEDIATELY DAMAGE THE ENGINE AND HYDRAULIC PUMP AND WILL NOT BE COVERED UNDER WARRANTY.

PACKAGE CONTENTS – PUSH MODELS

SKID

- 1 EA – HANDLE ASSEMBLY
- 1 EA – FRAME/ENGINE/CRADLE ASSEMBLY
- 2 EA – 4.80 X 12.0 WHEEL & TIRE
- 1 EA – PARTS BOX

PARTS BOX

- 1 EA – OWNER'S MANUAL
- 1 EA – ENGINE MANUAL
- 1 EA – WARRANTY CARD
- 1 EA – HITCH ASSEMBLY
- 2 EA – HUB ASSEMBLIES *** 030-0290 (NO THROUGH HOLE)
- 1 EA – BOLT BAG

*** - EACH HUB INCLUDES TWO (2) BEARINGS AND ONE (1) GREASE SEAL

BOLT BAG

- 2 EA – 1" SLOTTED HEX NUT 090-0663
- 2 EA – COTTER PIN 090-0657
- 2 EA – DUST CAP 702-0175 COMES WITH HUB
- 8 EA – 1/4"-20 LUG NUTS 090-0665 COMES WITH HUB
- 8 EA – 8" CABLE TIE 090-0668
- 2 EA – RING PIN & LANYARD 090-0549

COMPARE THE CONTENTS OF THE PACKAGE YOU RECEIVED WITH THE PARTS LIST ABOVE. IF THERE IS ANY DISCREPANCY CONTACT YOUR PLACE OF PURCHASE AT ONCE.

PACKAGE CONTENTS – SELF-PROPELLED MODELS

SKID

- 1 EA – HANDLE ASSEMBLY
- 1 EA – FRAME/ENGINE/CRADLE ASSEMBLY
- 2 EA – 4.80 X 12.0 WHEEL & TIRE
- 1 EA – PARTS BOX

PARTS BOX

- 1 EA – OWNER'S MANUAL
- 1 EA – ENGINE MANUAL
- 1 EA – WARRANTY CARD
- 1 EA – HITCH ASSEMBLY
- 2 EA – HUB ASSEMBLIES *** 030-0290 (NO THROUGH HOLE) 030-0349 (THROUGH HOLE)
- 1 EA – BOLT BAG

*** - EACH HUB INCLUDES TWO (2) BEARINGS AND ONE (1) GREASE SEAL

BOLT BAG

- 2 EA – 1" SLOTTED HEX NUT 090-0663
- 2 EA – COTTER PIN 090-0657
- 2 EA – DUST CAP 702-0175 COMES WITH HUB
- 8 EA – ¼-20 LUG NUTS 090-0665 COMES WITH HUB
- 8 EA – 8" CABLE TIE 090-0668
- 2 EA – RING PIN & LANYARD 090-0549

COMPARE THE CONTENTS OF THE PACKAGE YOU RECEIVED WITH THE PARTS LIST ABOVE. IF THERE IS ANY DISCREPANCY CONTACT YOUR PLACE OF PURCHASE AT ONCE.

ASSEMBLY

- **ASSEMBLY SHOULD BE DONE ON A CLEAN, DRY, LEVEL SURFACE**
1. Remove the handle, frame, engine and cradle assembly, tires and parts box from the shipping crate.
 2. The first step in assembly of the easy Auger will be to attach the highway service hubs, bearings and wheels. Inspect all four 1" tapered roller bearings. If they are not packed in grease, thoroughly pack them with high quality grease. Number 2-grade EP lithium 12-hydroxy stearate grease or equivalent is recommended. Place one of the bearings in the tapered race on the inside of the hub (the ribbed side of the hub). With the bearing inserted, place a bearing seal in the opening with the neoprene insert toward the bearing and tap firmly in place. Use caution to insure no distortion occurs to the seal. Cover the seal with a block of wood and tap equally around the perimeter until the seal is flush with the hub face. Turn the hub over and partially fill the hub cavity with grease. Slide the hub onto the axle shaft. Place the second tapered bearing on the shaft and slide it into the race inside the hub. Place the 1" slotted hex nut on the threads of the axle shaft and tighten securely enough to help seat the tapered roller bearings. At the same time turn the hub in both directions until there is a slight bind to be sure that all the bearing surfaces are in contact. Back the nut off just enough (1/4 turn) to allow the hub to rotate freely. Place the cotter pin through the hole in the end of the shaft and through the slots in the nut. Bend the legs of the cotter pin in opposite directions around the nut. Place a small amount of grease in the dust cap and mount to the end of the hub. Attach the tires to the hubs with four lug nuts. Tighten securely.

NOTE FOR SELF-PROPELLED MODELS: The hub with the cross-hole must be installed on the left side of the machine from the operator position.

3. To attach the handle to the machine hold it upside down, with the shaft of the bit motor pointing up. Insert the handle into the frame tube until it stops or bottoms out. Rotate the handle until the bit motor is upright. This allows the retaining rod in the frame to hook into a slot in the end of the handle and keep the parts together.
4. Uncoil all hoses and the wire harness from around the engine.
5. The hydraulic hose and wire harness will be routed to the left hand side of the frame, through the cushioned clamps and then to the control valve. Attach the hose from the pump in the top clamp, and the return line going back to the filter should be in the bottom clamp.
6. The wire harness will follow these hoses, but do not put in the hose clamps.
7. **IMPORTANT:** To ensure proper hydraulic fluid flow, the hoses must be connect to the proper points. The hose from the pump connects to the "IN" side of the control valve, and the return hose connects to the "OUT" side of the valve.

NOTE: CHECK THE PARTS DIAGRAM FOR COMPLETE ROUTING OF ALL HOSES.

8. Fasten the wire harness to the hoses with the enclosed cable ties. Route the wire under the handle where the handle and frame meet. Bring the harness up the right side of the handle and attach to the stop switch.
NOTE: If the stop switch doesn't work per the decal, reverse the wires on the bottom of the switch.
9. Fill the hydraulic oil tank to within 1" of the top of the tank (about 8-1/2 quarts). Use a premium quality industrial anti-wear hydraulic fluid. The tank is to be filled through the top of the return filter. Unscrew the top of the filter, remove the element, and fill to the appropriate level. Replace element and filter cap.
10. Add oil to the engine per the engine owner's manual. Failure to do so will cause damage to the engine or machine, which will not be covered under warranty.
11. Add gasoline and start the engine per the engine manual.
12. Cycle the bit and wheel drive motor in both directions (forward and reverse) quite a few time to purge the system of air and to get fluid running throughout. Recheck fluid level and add if required.
13. To get maximum performance from your Auger, it is important that the control valve move equal amounts in both directions when engaged by the control lever. If this is not the case, adjust the control rod until you have equal travel in both directions.

SECTION II - OPERATING INSTRUCTIONS

PRE-START CHECKLIST

Before attempting to operate the Easy Auger, several important checks of the engine and hydraulic system are critical. Potential problems can be avoided by proper attention to maintenance.

1. Familiarize yourself with the Easy Auger Owner's Manual and the Engine Operating and Maintenance Instructions.
2. Check all hydraulic hoses and fittings for any signs for leakage or wear.
3. Check the entire machine for any loose nuts or bolts, electrical connections or fuel connections.
4. Check the control lever for any sticking or binding.
5. Check the level of all fluids and fill accordingly. (See Maintenance Section for recommendations.)
6. Check the auger for worn or damaged flighting, dull teeth, or a worn pilot bit.

**COPY PAGES 11 - 15 AND
GIVE TO THE USER OF
THIS AUGER**

USING THE EASY AUGER

SAFETY FIRST

Before using the Easy Auger familiarize yourself with all the controls and their functions. Review all the safety warnings and cautions found on the machine. Please review the illustrations in Appendix B in the rear of this manual for information regarding the Easy Auger.

1. Operating Control Lever – Illustration #1 & #2

The operating control lever is the hand-operated lever that pivots left or right and controls the rotation of the drilling auger bit. When operating the Easy Auger, always keep both hands firmly grasped to the frame handle and the operating control lever.

2. Engine Stop Switch – Illustration #1

There are two engine stop switches on the Easy Auger. One switch is mounted on the engine and the other is mounted on the auger control handle. Both switches must be in the “ON” position before the engine will start.

3. Auger Head Locking Clamp – Illustration #1

The locking clamp secures the auger head assembly (auger, motor, control lever, etc.) from rotating. The locking clamp may be loosened to pivot the entire Assy to allow for drilling on the side of a hill or uneven ground. Always re-tighten the locking clamp before drilling.

4. Auger Motor Plate Locking Pin – Illustration #1

The locking pin prevents the auger bit from freely swinging back and forth when moving the entire machine from place to place. When the auger bit hydraulic motor plate is locked in place the machine can be moved without the auger bit moving. Always lock the hydraulic motor plate before moving to the next drilling position.

5. Double Selector Valve, (SP Units Only) – Illustration #1

The Self Propelled Easy Auger is equipped with a two-position double selector valve mounted on the right-hand side of the control handle assembly. The position of the spool will determine if the wheel drive motor is engaged or the auger drive motor is engaged. If the Selector Knob is pushed “IN” the wheel drive motor circuit is activated. If the Selector Knob is pulled “OUT” (toward the operator) the auger drive circuit will be activated.

6. Tow Hitch: Ref. Illustration #3

The tow hitch secures the Easy Auger to your vehicle, which must be equipped with a 2” ball. Secure the coupler over the ball by locking down the lever and securing with cotter pin. Be sure to check that the coupler jaw completely grasps the hitch ball. When you arrive at your destination leave the coupler attached to the ball and remove the two pins securing the hitch to the auger frame. From the handle end pull down on handle to free hitch from auger.

7. Locking Hub (SP Units Only) - Illustration #3

To switch the SP unit from tow mode to self-propelled mode it is necessary to take one of the pins used to secure the tow hitch to the auger and place through the hole on the locking hub which secures the hub to the drive axle.

DRILLING A HOLE WITH THE EASY AUGER

1. Check with all area utilities before drilling any hole. Buried pipes and cables may be under the surface where you intend to dig. Never drill a hole before you are aware of what might be beneath the surface of the ground.
2. Remove the auger motor locking pin so the auger drilling head is free to rotate.

WARNING: THE ENGINE MUST BE "OFF" WHEN ATTACHING OR REMOVING AUGER BITS FROM THE DRIVE MOTOR.

3. Attach the proper diameter auger to the drilling head hydraulic motor using the quick release pin. The pin will prevent the auger from falling off of the hydraulic motor.
4. Start the engine. Drill at full throttle of 3600 RPM.
5. Position yourself behind the unit in a comfortable stance. Grasp the control handle and the operating lever with both hands. Keep your legs and feet clear of the auger at all times. Proper attire will include safety glasses and work boots.
6. When the operating lever is pulled towards the control handle with the right hand, the auger will begin to rotate in a clockwise direction into the ground. A minimum amount of travel is required before the auger begins to rotate. Be Prepared!
7. Exert downward pressure on the control handle to start the drilling process. Once the auger bit enters the ground, carefully monitor the depth. Stop the auger and clear the loose dirt from the hole frequently. The dirt can be cleared by lifting the auger clear of the hole. The auger wheels must be free of any obstructions during the drilling process. It will be necessary to move the machine (Ref. Illustration #3) forward or backward while drilling to maintain a vertical hole.
8. Ground conditions and soil type will affect how the Easy Auger operates. Loose sandy type soils are easy to drill and require a minimum of effort. The RPM of the auger will remain constant and the engine will not labor. Heavier types of soil such as clay will require more downward pressure and engine horsepower. As the force required to drill a hole increases the RPM of the auger will slow in proportion. This is a normal condition. The auger will cease to rotate once the resistance of the ground exceeds the torque of the hydraulic motor. A high-pitched squealing noise can be heard from the control valve when the auger stops rotating. Release the operating control lever to neutral immediately! The noise is caused by hydraulic fluid passing the internal relief valve. This condition causes a rapid heat build up in the hydraulic fluid and must be avoided. If the auger stops rotating, reverse the direction of rotation by pulling the operating control lever with the left hand. The auger should then back out of the ground in a counter-clockwise rotation.

The auger may stop rotating for a number of reasons. Underground rocks and tree roots are commonly encountered while drilling. These obstructions will have to be cleared before drilling can continue.

Heavy wet soil poses a different drilling problem. The auger can literally "pull" itself into the ground when drilling in this type of condition. If the auger starts to pull downward without the operator exerting any pressure, stop immediately and clear the hole. Heavy wet soil will also stick to the auger flights and shaft; clean the auger frequently in this type of condition.

The diameter of the auger used will also affect the ability of the machine to drill a hole. The larger the diameter of the auger, the more torque required to dig. If the auger frequently stalls while operating it may be necessary to drill a hole of smaller diameter first and then finish the job with a larger unit.

9. When drilling on uneven or sloping ground (Ref. Illustration #4) special precautions must be taken. Never drill a hole on a slope with the machine parallel to the slope. The operator must never be above or below the machine in this circumstance. Always position the machine across the slope for this type of condition. To drill a vertical hole, it will be necessary to rotate the control head of the auger. Loosen the auger head-locking clamp and rotate the auger control handle until the drill is vertical to the ground; tighten the clamp securely and proceed as normal. The maximum grade the Easy Auger can operate on is 15 degrees.

10. Once you have completed drilling:
 - A) Stop the engine
 - B) Remove the Auger from the Hydraulic Motor.
 - C) Lock the hydraulic drive motor plate in place.

11. If towing the Easy Auger SP it is extremely important to disconnect the locking hub by removing the locking pin from the hub. To install or remove the locking pin it may be necessary to roll the tire forward or backwards to align holes. The pin must then be used to secure the hitch to the auger frame.

OPERATING THE SELF-PROPELLED WHEEL DRIVE

1. Remove tow hitch from the auger per previous instructions.
2. Insert one of the two pins that secure the hitch into the hole in the hub of the drive side wheel assembly (LH side from the operator position). Secure the pin with the attached cotter pin. It may be necessary to roll the tire back and forth to align the holes and insert the pin.
3. Push the knob on the 6-way valve towards the engine to engage the wheel drive motor.
4. Pull the control lever with your right hand for forward drive and your left hand for reverse.
5. **If towing the self-propelled Easy Auger, it is extremely important to remove the pin in the hub.** Failure to do this will damage the wheel drive motor. This pin is then required to attach the hitch to the auger frame.

ILLUSTRATION #2

OPERATING CONTROL LEVER POSITIONS

OPERATOR END

ENGINE END

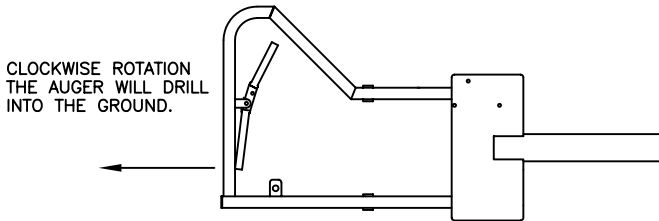
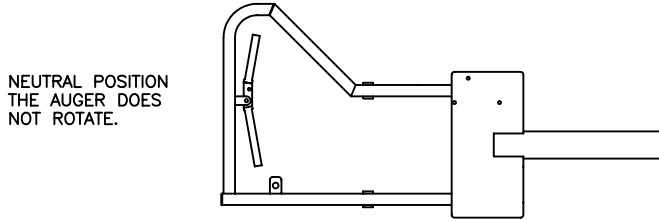
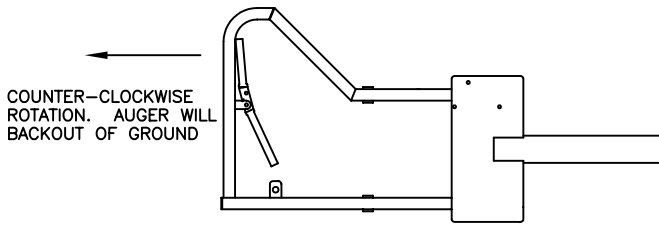

STANDARD & SELF PROPELLED

ILLUSTRATION #3

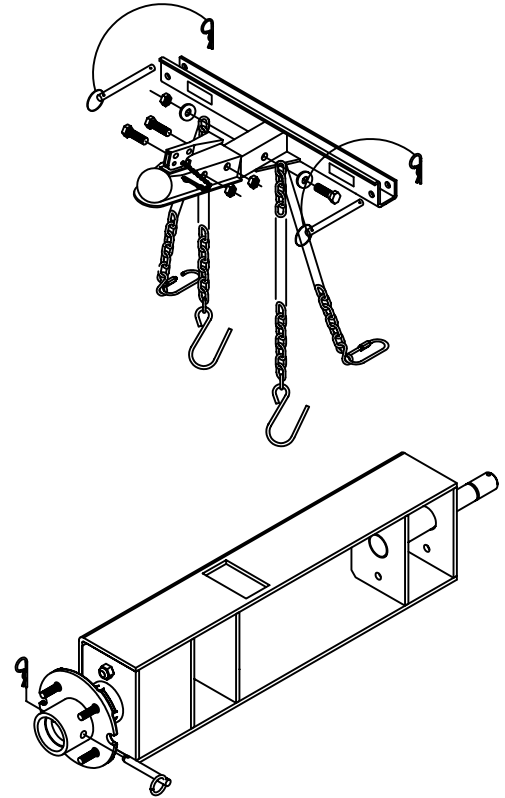

STANDARD & SELF PROPELLED

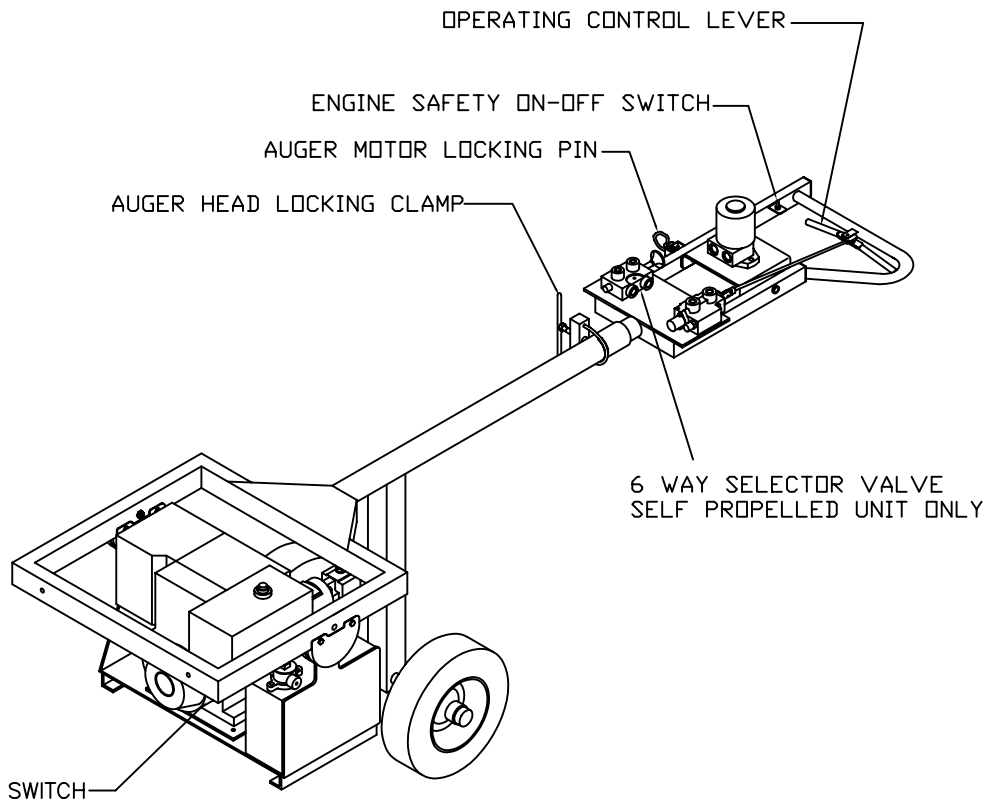

APPENDIX B

ILLUSTRATION #1

ILLUSTRATION #4

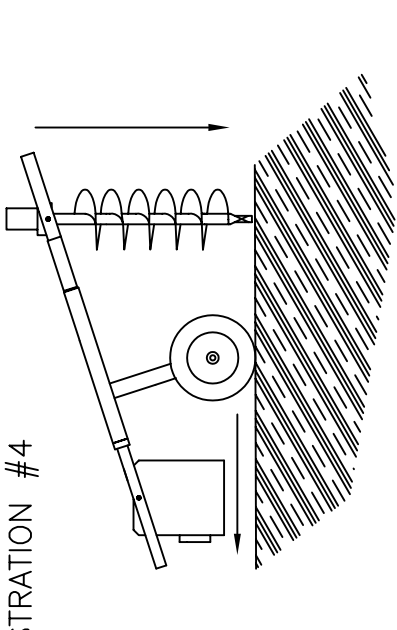

THE EASY AUGER WHEELS MUST BE FREE TO MOVE FORWARD OR OR BACKWARD WHEN DRILLING A HOLE. AS THE AUGER ENTERS THE GROUND THE DISTANCE BETWEEN THE AUGER WHEELS AND THE HOLE WILL CHANGE. THE OPERATOR MUST MOVE THE MACHINE IN ORDER TO DRILL A VERTICAL HOLE.

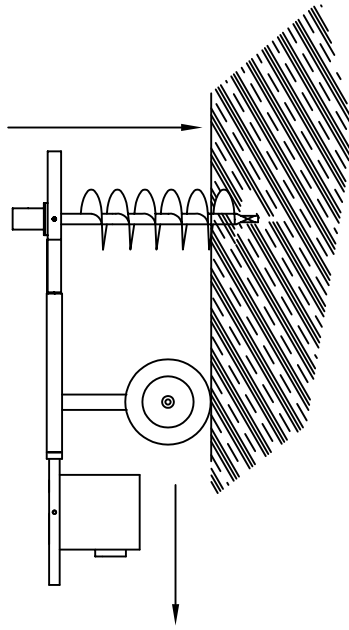

AS YOU CAN SEE BY THIS ILLUSTRATION THE DISTANCE BETWEEN THE AUGER AND THE WHEELS CHANGES THE DEEPER THE HOLE IS DRILLED. THE MACHINE HAS TO BE PUSHED FORWARD IN ORDER FOR THE HOLE TO BE DRILLED VERTICALLY.

ILLUSTRATION #4A

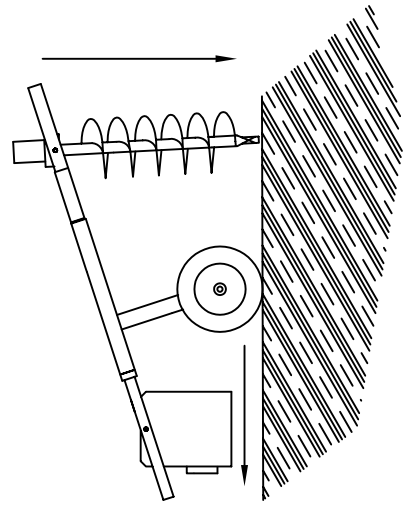

START A HOLE WITH THE AUGER ANGLED SLIGHTLY TO THE REAR THE MACHINE WILL HAVE TO BE ADJUSTED TOWARDS THE REAR INITIALLY BUT THEN FORWARD TO COMPLETE THE HOLE. IT WILL MINIMIZE THE TOTAL AMOUNT OF TRAVEL FORWARD REQUIRED.

ILLUSTRATION #5

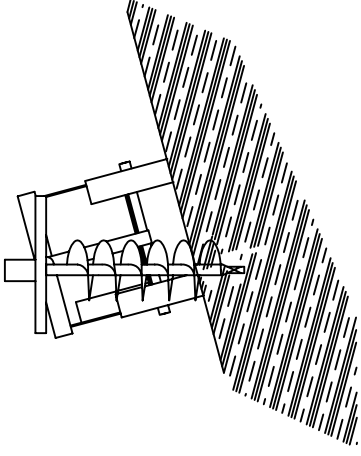

WHEN DRILLING ON A SLOPE ALWAYS POSITION THE MACHINE ACROSS THE SLOPE.

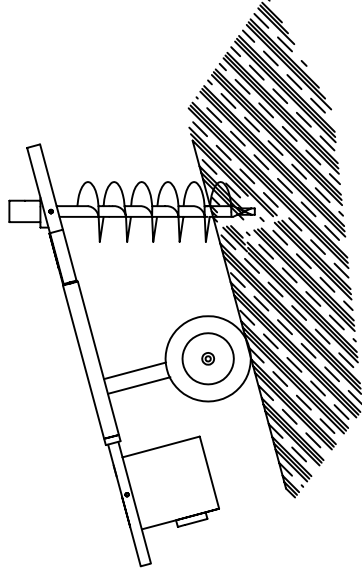

NEVER DRILL ON A SLOPE WITH THE MACHINE POSITIONED DOWNHILL.

ILLUSTRATION #5A

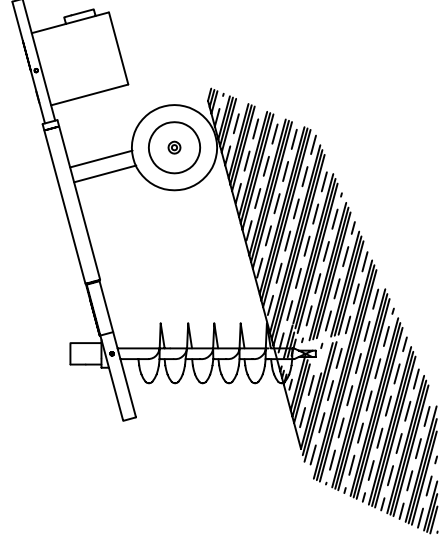

NEVER DRILL ON A SLOPE WITH MACHINE POSITIONED UPHILL.

ADDITION NOTES

- **WARNING:** Never move the selector knob unless the hand control lever is in the center or neutral position. Sudden movement of the machine or auger rotation could occur.
- With the Selector Knob in the IN position slowly pull the control lever toward the control bar with the right hand, the Easy Auger will move forward. To stop the Easy Auger release the control lever to the neutral or center position. To reverse the direction of the Easy Auger pull the control lever slowly toward the handle bar with the left hand. To stop the Easy Auger, release the control handle to the center position.
- **CAUTION:** Moving the control lever handle rapidly in either direction will cause the machine to abruptly start or stop.
- Check with all area utilities before drilling. Buried pipes and cables may be under the surface where you intend to dig. NEVER drill a hole before you are aware of what might be beneath the surface.
- Do not operate the Easy Auger while under the influence of alcohol, drugs or medication. A clear mind is essential for safety.
- Do not allow anyone who is not alert to operate this machine.
- See Appendix A for a list of phone numbers for your Local One Call Center.
- **WARNING:** The engine must be off when cleaning the auger drill bit. Serious injury will occur if the hydraulic drive motor should begin rotating.
- The diameter of the auger used will also affect the ability of the machine to drill a hole. The larger the diameter of the auger, the more torque required to dig. If the auger frequently stalls while operating it may be necessary to drill a hole of smaller diameter first and then finish the job with a larger unit.
- When drilling on uneven or sloping ground (see pg 31) special precautions must be taken. NEVER drill a hole on a slope with the machine parallel to the slope. The operator must never be above or below the machine in this circumstance. Always position the machine across the slope for this type of condition. To drill a vertical hole it will be necessary to rotate the control head of the auger. Loosen the auger head locking clamp and rotate the auger control handle until the auger bit is vertical to the ground; tighten the clamp securely and proceed as normal. The maximum grade the Easy Auger can operate on is 15 degrees.

TRANSPORTING THE EASY AUGER

- The Easy Auger will fit easily on the bed of a small trailer or in the box of a pickup. The push and SPT models can also be towed with a trailer hitch kit.
- **WARNING:** When loading or unloading the Easy Auger never grip the side members of the engine cradle frame. Pinch points occur when the cradle rotates inside the frame.
- **WARNING:** The engine shall be off when removing or attaching auger drill to the hydraulic drive motor. Serious injury can occur if the hydraulic drive motor should begin rotating.
- **WARNING:** The auger must be removed from the hydraulic drive motor before the Easy Auger can be transported. The auger "SHALL NOT" remain attached while the unit is being towed or tailored.

- **WARNING:** Stop the auger rotation and turn off the engine before attempting to remove the auger from the hydraulic motor. Serious injury could result from contact with the rotating auger bit.
- Review the assembly and towing instructions that are contained with. Insure all pins are locked in place and safety chains are connected to the tow vehicle and through the tow eyes on the auger frame before moving.
- When towing the Easy Auger care must be taken to insure that the towing vehicle is equipped with the proper size ball hitch. The Easy Auger Hitch Kit is available in one size with a 2" ball coupler. Do not use a 1 7/8" ball. It is too small. A 2" ball must be used.
- **WARNING:** Do not exceed 45 MPH when towing the Easy Auger. Exceeding the 45 MPH limit could result in damage to the Easy Auger and unsafe towing conditions. Always slow down when crossing train tracks, potholes, or any other items in or on the road that might cause the Easy Auger to bounce, ride unevenly or tip over. Always use care and common sense when towing the Auger. Do not tow in a manner that would not conform to the conditions or environment when towing.

SECTION III - MAINTENANCE

The Easy Auger has been designed to operate with a minimum of maintenance and service.

Engine

Consult the Owners Service and Maintenance Manual provided by the engine manufacturer.

Hydraulic Fluid

The hydraulic fluid used in the auger system will influence the performance and durability of the individual components. A Premium Quality Industrial Anti-Wear Hydraulic Fluid is recommended for usage in this system.

Hydraulic Tank Capacity

The Easy Auger requires 8.5 qts. (8.04 L) of fluid. The fluid level should be 1" from the top of the tank (7.62 cm) when the unit is properly filled. The fluid level should always be within 4" of the top of the tank. To add fluid to the hydraulic tank remove the cap on the return filter body located on top of the hydraulic tank. Remove the filter element from the tank by grasping the tab in the center of the filter



and pulling up on the element. Always fill or check the level of the fluid in the tank with the filter element removed.

CAUTION: Do not overfill the hydraulic tank. Room must be left in the tank for fluid expansion caused by higher fluid temperatures during operation.

Visually inspect the oil every month. Compare the color and body with an unused sample of the same

oil. A slight darkening is not serious, but a deep dark color or noticeable thickening may suggest serious deterioration. Any fluid that has a gritty feel or a burnt odor must be replaced. Normal operating conditions would dictate a fluid change every 1500 hours, or a minimum of once each operating season.

Hydraulic Oil Filters

The Easy Auger is equipped with two filtering devices. The hydraulic pump intake hose is connected to an internal tank suction strainer with a 100-mesh screen. There is also a replaceable 10 micron filter that is in the return filter to the tank. The tank suction strainer should be inspected and cleaned and the 10-micron filter should be replaced every 750 hours of normal operations.

To clean the suction strainer first drain all the fluid from the hydraulic tank. There is a .5" drain plug in the bottom of the tank for this purpose. Disconnect the intake hose at the hydraulic pump first and then unscrew the hose from the hydraulic tank fitting. The suction strainer is now accessible by unscrewing the pipe fitting from the tank.

Clean the strainer by back flushing with an approved cleaning agent or with an air nozzle, by blowing the screen clean.

Always replace the 10 micron filter with a new filter. Never reuse an existing filter.

Reverse the above procedure and refill the oil tank to the required level. Start the engine and cycle the auger to clear any air in the lines and check for leaks at loose fittings or hoses. Re-check the level of the fluid in the tank and add if necessary.

Dispose of all contaminated fluids and used filters properly.



CAUTION: Operating conditions will affect the frequency of fluid maintenance. Extremely hot dusty conditions will require diligent monitoring of the system to insure the fluid does not become contaminated and deteriorate.



CAUTION: The suction strainer “is not” equipped with a bypass valve. If the strainer should become plugged with debris this could cause the hydraulic pump to cavitate and damage the rotors.

Hydraulic Hose Routing

Each hydraulic hose is of a specific length and size and must be routed to the proper ports. Incorrect connections could result in improper operation or component failure. Check the hose routing diagram in this manual to verify hose routings.

Control Rod and Lever

Control rod and lever adjustment is critical to the proper operation of the hydraulic directional control valve. The control valve must be engaged fully in each direction for proper fluid flow through the system. An improperly adjusted rod will be evidenced by auger rotation occurring one direction only or much faster rotation when reversed. Total travel of the control valve spool is .25" (6.35mm) in or out from center.

Adjust the control rod by removing the nut and lock washer that secure the ball joint to the control lever; with the ball joint free of the lever loosen the jam nut between the ball joint and the control rod, also

loosen the jam nut at the control valve eyelet. With both jam nuts free, the control rod length can be changed by turning the rod into or out of either the ball joint or the control valve eyelet. Replace the ball joint in the control lever; measure travel of the control valve spool in each direction. The travel should be equal .25" (6.35mm) in or out. Retighten the jam nuts and the nut and lock washer on the ball joint. Start the engine, engage the control lever and observe the rotation of the auger in each direction. Repeat the above steps as necessary.

Directional Control Valve

The directional control valve is equipped with an internal relief bypass that has been preset at the factory at 2750 PSI. This setting must be maintained to insure efficient auger performance and to protect the hydraulic motors. If adjustment to the control valve bypass is required, the following procedure must be followed.

A 3000 PSI (210.9 KG/Sq.cm) pressure gauge must first be installed in either of the two lines between the double selector valve and the auger drive motor.



CAUTION: The Double Selector Valve Control Knob must be in the OUT position when performing this test.

A method of applying resistance to the flow of fluid through the hydraulic motor is also necessary. A needle valve may be used in line with the pressure gauge or a mechanical means of preventing the hydraulic auger motor adapter shaft from rotating when pressure is applied. Remember the motor is capable of 360 ft./lbs. of torque so whatever clamping device used must be substantial. With the engine running at 3600 RPM slowly engage the control lever and watch the pressure gauge.

Remember the pressure will only register on the gauge when that line is pressurized. With the control lever fully engaged and the hydraulic motor immobilized or the flow restricted with a needle valve the pressure gauge should read 2750. To adjust the pressure setting of the valve, release the control lever and shut off the engine. Remove the 13/16 elongated crown nut on the end of the control valve. The nut is at the end of the valve opposite of the control rod. Inside the nut will be found a threaded screw with a recessed hex key end. A 5/16 hex key wrench is required to turn the screw. One revolution of the threaded screw clockwise will increase the pressure setting by 500 PSI (35.15 Kg/sq.cm); one revolution counterclockwise will reduce the pressure 500 PSI (35.5 Kg/sq.cm). If a pressure change is necessary, turn the screw only 1/8 turn at a time in the appropriate direction, replace the crown nut and tighten securely. Restart the engine and check the pressure setting as before. Repeat the above procedure until the proper pressure setting is obtained. If the valve cannot be adjusted to the proper pressure range, contact an authorized dealer or service center.



CAUTION: The pressure setting of the bypass relief valve must never exceed 3000 PSI. The valve is rated to 3000 PSI, and damage to the hydraulic system could occur at elevated pressures.

Hydraulic Pump

The hydraulic pump is a two-stage pump and has an internal relief setting of 1500 psi. This relief controls the bypass flow of the first gear set. The second gear set is controlled by the 2750 psi relief setting on the control valve. This pump should be able to handle 2750 psi continuously and 4000 psi intermittently. The flows should be approximately

7-8 gpm up to 1500 psi at which point it should drop to approximately 3.5 – 4.5 gpm.

To replace the pump first drain the hydraulic fluid from the tank. Disconnect the intake and output hoses from the pump. A small amount of hydraulic fluid will remain in the pump and the lines after draining the tank so precautions must be taken to prevent spillage. Remove the upper housing guard from the pump to engine bell housing. Remove the four cap screws mounting the pump to the bell housing. Pull straight back on the pump to separate the couplings inside the bell housing; one coupling will come with the pump along with the insert from the end of the bell housing. Loosen both of the set screws on the coupling and remove the coupling from the pump shaft. Remove the housing insert at the same time and save for remounting the new pump.

When remounting a pump first place the bell housing insert against the pump face and then slide the coupling onto the pump shaft. Leave approximately .125" (3.1mm) clearance between the pump coupling and the insert. Tighten both of the coupling set screws. Insert the pump into the end of the bell housing with the larger of the two ports oriented down. Replace and tighten the four cap screws with lock washers.

Care must be taken to prevent any end load on the pump shaft. Measure the distance between the two couplings. At least .125" (3.1mm) must separate the two couplings. If necessary, loosen the two setscrews on the engine shaft coupling and move it in or out to establish the correct distance. Re-tighten all setscrews, replace the housing guard, reconnect the intake and outlet hoses, refill the hydraulic fluid and test the unit.

Hydraulic Drive Motors

No maintenance or adjustments can be made to the hydraulic drive motors.

Hydraulic Fittings

The SAE O-ring fittings require no thread treatment to prevent leakage. Do not use Teflon or plastic tape to seal the threads; these materials promote over tightening and are not recommended.

Hydraulic Service

If service or repair is required on any of the hydraulic components contact your nearest authorized dealer or service center.

Wheels

The Easy Auger is equipped with high-speed highway service wheels and tires. The wheels are a fixed hub integral design with two 1" high speed tapered roller bearings. The bearings should be checked for grease and serviced annually. **To confirm correct PSI requirement, check tire sidewalls for recommended PSI.**

If towing the self-propelled Easy Auger, it is extremely important to remove the pin in the drive hub. Failure to do this will damage the wheel drive motor. This pin is required to attach the hitch to the auger frame.

Auger Adapter

The Easy Auger is equipped with an adapter that connects the hydraulic drive motor to the auger drill bit. The adapter can be removed from the hydraulic motor by removing the roll pin that attaches the

adapter shaft to the adapter body, and then removing the bolt that attaches the adapter body to the bottom of the motor shaft. The adapter will then slide off the end of the hydraulic motor shaft. To replace the adapter, reverse the above procedure.

Cradle, Drive Mount, Locking Handle

Lightly grease or oil all of the shoulder bolts and pivot points on the cradle and drive mount. Grease the threads on the locking handle and put a small amount of grease inside the cup that holds the locking handle threaded rod in place.

Hydraulic Motor Plate Locking Device

The hydraulic motor plate is equipped with a locking device to prevent movement during towing or moving about a job site.

The hydraulic drive motor plate is held in place by a spring loaded locking pin. To release the pin from its holding bracket grasp the D-handle of the pin and rotate the pin 90 degrees to clear the slots in the bracket. Align the hole in the hydraulic drive motor plate with the pin and release the pin. The spring tension will hold the pin in place through the hydraulic motor plate. The locking pin must secure the hydraulic drive motor plate before the unit can be towed.

Drive Shaft Bearings

After every 8 hours of operation, lubricate the drive axle bearings. To do this, wipe all dirt, etc., from the grease fittings with a clean cloth, then apply no more than 3 shots of quality general-purpose grease with a hand-pumped grease gun. Over lubrication can also damage bearings. Also, check the bearing collar set screws regularly to be sure they are tight. If they are loose, reset them with Loctite 243, obtainable at any hardware store.

TROUBLE SHOOTING

PROBLEM:

The auger rotates slowly or will not rotate at all.

REMEDY:

1. Check control rod adjustment and readjust if necessary
2. Check fluid level in the tank; fill as required.
3. Confirm proper hose routing.
4. Insufficient pump pressure; test pump.
5. Suction strainer plugged. Clean or replace.
6. Incorrect bypass valve pressure setting.

PROBLEM:

Control valve emits continuous squealing noise when the auger is engaged, bypass valve open.

REMEDY:

1. Auger stuck on obstruction, reverse direction of rotation and clear auger.
2. Incorrect bypass valve pressure setting.

PROBLEM:

Auger rotates in one direction only or faster in one direction than the other.

REMEDY:

1. Check control rod adjustment; the control rod must move equal-distant in each direction.

PROBLEM:

Engine will not start, runs poorly, and lacks power.

REMEDY:

1. See Engine Owners Manual included with the unit.

SECTION IV - AUGER PARTS LIST

ITEM #	PART #	QTY	DESCRIPTION
1	090-0470	10	1/4-20 NYLOCK NUT
2	090-0662	2	3/8" CUSHIONED CLAMP
3	850-2910	1	PIPE CAP
4	850-4286	1	OIL DRAIN ASSY
5	850-7098	1	OIL DRAIN ADAPTER – HONDA ENGINE
5	850-7099	1	OIL DRAIN ADAPTER – B&S INTEK IC & ROBIN ENGINE
6	030-0288	1	9 HP HONDA
6	030-0447	1	9 HP ROBIN
7	090-0639	10	5/16-18 THIN NYLOCK NUT
8	090-0233	4	5/16 USS FLATWASHER
9	850-0010	1	ENGINE MOUNT PLATE
10	850-1148	4	MOTOR MOUNT
11	850-7085	8	ADAPTER, 90DEG WITH O-RING
12	850-5003	1	CRADLE WELDMENT
13	850-8303	1	90" HOSE, FILTER TO CONTROL VALVE
14	850-2920	1	1/2" PLUG
15	090-0661	5	3/4" CUSHIONED CLAMP
16	850-2845	1	SUCTION STRAINER
17	850-8276	1	18" HOSE, PUMP TO TANK
18	030-0494	1	RETURN FILTER
19	090-0476	2	5/16 SAE FLATWASHER
20	090-0113	4	3/8-16 X 1-3/4" HHCS
21	090-0234	6	3/8" FLATWASHER
22	090-0461	9	3/8-16 NYLOCK NUT
23	850-0022	1	WIRE HARNESS
24	090-0228	12	3/8" LOCKWASHER
25	090-0111	2	3/8-16 X 1-1/4" HHCS
26	850-7051	1	ADAPTER, PUMP INLET
27	850-0087	1	HYDRAULIC PUMP
28	850-8287	3	66" HOSE, PUMP TO CONTROL VALVE & WHEEL MOTOR
29	090-0066	4	5/16-18 X 3/4" HHCS
30	090-0394	4	5/16" LOCKWASHER
31	090-0664	1	#5 WOODRUFF KEY, PUMP SHAFT
32	850-2847	1	INSERT, PUMP MOUNT
33	850-2843	2	PUMP MOUNT COVER
34	850-2840	1	PUMP TO ENGINE MOUNT HOUSING
35	850-9014	1	COUPLING, 1/2" X .125"
36	850-9018	1	COUPLING INSERT
37	850-9017	1	COUPLING, 1" X .25"
38	500-0031	1	1/4" X 1/4" X 1" KEY
39	090-0110	8	3/8-16 x 1" HHCS
40	850-0088	1	AUGER BIT HYDRAULIC MOTOR
41	850-7057	4	ADAPTER, MOTOR PORT
42	850-8305	1	30" HOSE, CONTROL VALVE TO MOTOR
43	850-8306	1	36" HOSE, CONTROL VALVE TO MOTOR
44	850-7087	4	ADAPTER, 90d SWIVEL
46	850-6001	1	COMPLETE DRIVE ADAPTER WITH HARDWARE
48	090-0655	1	CLEVIS PIN 1/4" X 2"
49	850-1205	1	PIN, EXPANSION
50	850-4998	1	PIVOT PIN
51	090-0656	1	HAIR PIN
52	090-0660	4	SHOULDER BOLT
54	850-4997	1	BRACKET, PIN
55	850-1204	1	SPRING, PIVOT PIN

56	850-8300	2	24" HOSE, SELECTOR VALVE TO CONTROL VALVE
57	850-7084	4	ADAPTER, CONTROL VALVE
58	090-0115	3	3/8-16 X 2 1/2" HHCS
59	850-3614	1	SELECTOR VALVE, 6 WAY
60	850-0075	1	LOWER HANDLE WELDMENT
61	090-0057	2	1/4-20 X 1-1/2" HHCS
62	850-0092	1	CONTROL VALVE, 4-WAY RELIEF
63	090-0651	1	CLEVIS PIN 3/16" X 7/8"
64	090-0652	1	COTTER PIN 1/16" X 1/2"
65	850-1171	1	BUSHING, 3/16" X 5/16"
66	850-1172	1	EYELET, CONTROL ROD
67	090-0265	3	1/4-28 HEX NUT
68	850-0081	1	CONTROL ROD
69	090-0013	3	1/4-20 X 1-3/4" HHCS
70	850-0070	1	CONTROL LEVER
71	090-0264	1	BALL JOINT
72	090-0717	1	5/16 DIA X 1/2 LONG SHOULDER BOLT
73	090-0223	1	1/4" INT/EXT LOCK WASHER
75	850-0019	1	STOP SWITCH
76	090-0629	2	1/2-13 NYLOCK NUT
77	850-0091	1	BIT MOTOR WELDMENT
78	850-0069	1	HANDLE TIGHTENER
79	850-0051	1	FRAME WELDMENT – SELF-PROPELLED UNITS
79	850-0059	1	FRAME WELDMENT – PUSH MODELS
80	090-0065	3	5/16-18 X 1/2" HHCS
81	850-4866	4	SHIELD SIDE
82	090-0405	4	1/4-20 X 2-1/4" HHCS
83	030-0349	1	DRIVE SIDE HUB
84	702-0175	2	DUST CAP
85	090-0663	2	SLOTTED HEX NUT
86	090-0657	2	COTTER PIN
87	090-0665	8	LUG NUTS
88	030-0207	2	480 x 12 WHEEL & TIRE ASSEMBLY
89	850-0093	1	CLAMP
90	090-0549	1	RING PIN & LANYARD
91	850-0025	1	DRIVE AXLE
92	090-0654	2	3/8-16 THIN NYLOCK NUT
93	850-0024	1	COUPLER
94	710-3084	2	3/8-16 X 2 3/4" HHCS
95	030-0290	1	HUB – 1 SELF-PROPELLED UNITS, 2 PUSH UNITS
97	030-0340	2	BEARING
98	090-0550	4	3/8-16 X 1 1/2" CARRIAGE BOLT
99	090-0098	4	3/8-16 X 3/4" HHCS
100	850-6102	1	WHEEL DRIVE MOTOR
101	850-0053	1	CENTER TUBE
102	090-0510	2	1/2-13 X 4" HHCS
103	030-0491	2	GRIP – CONTROL LEVER
104	090-0714	1	1/2-13 X 4" WIDE U-BOLT FOR 3-1/2" PIPE
105	090-0628	4	1/2-13 JAM NUT
106	850-0080	1	UPPER HANDLE WELDMENT

04/19/11

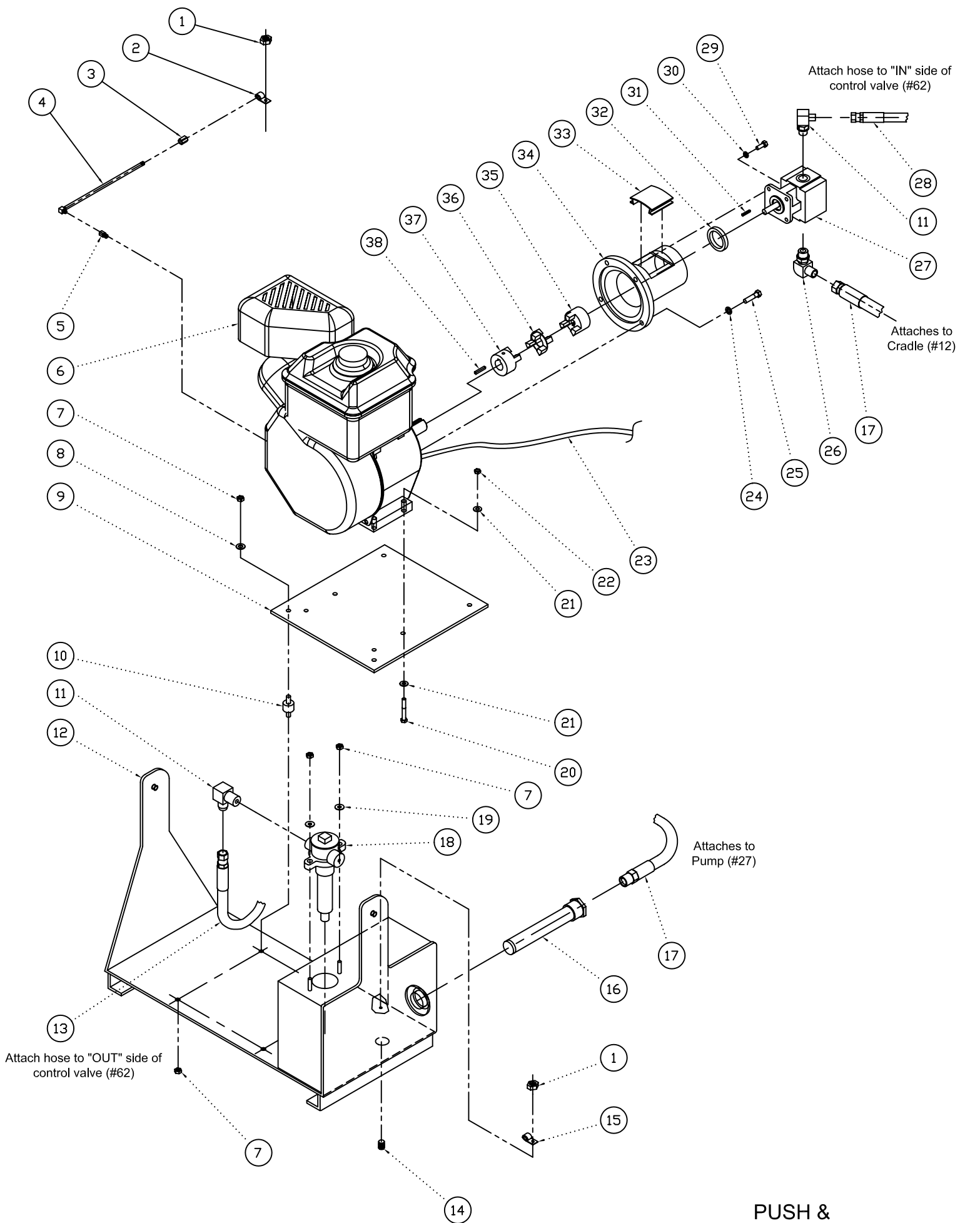

ENGINE & CRADLE

PUSH &
SELF-PROPELLED

HANDLE ASSEMBLY SELF-PROPELLED MODELS

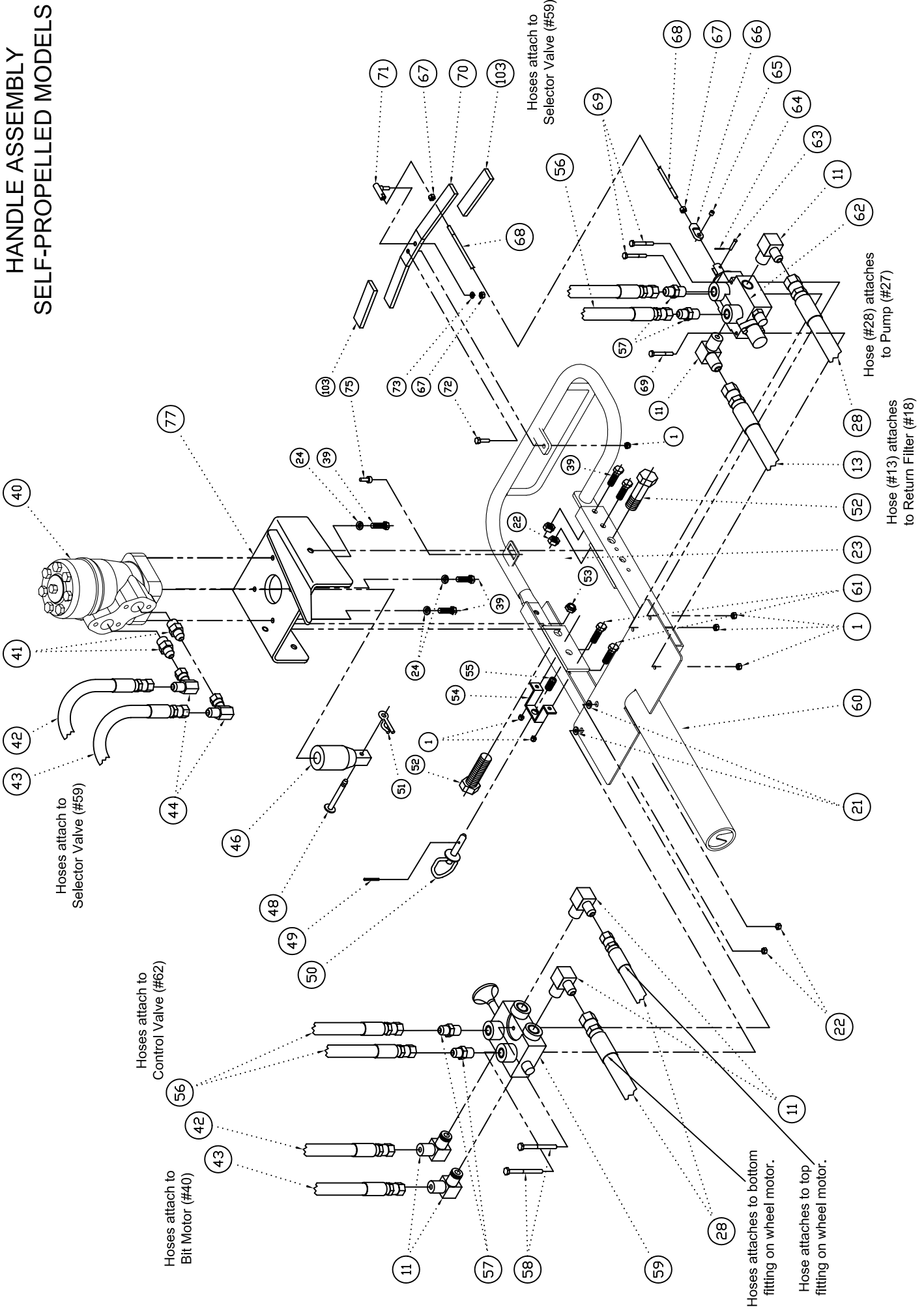

FRAME ASSEMBLY
SELF-PROPELLED MODELS

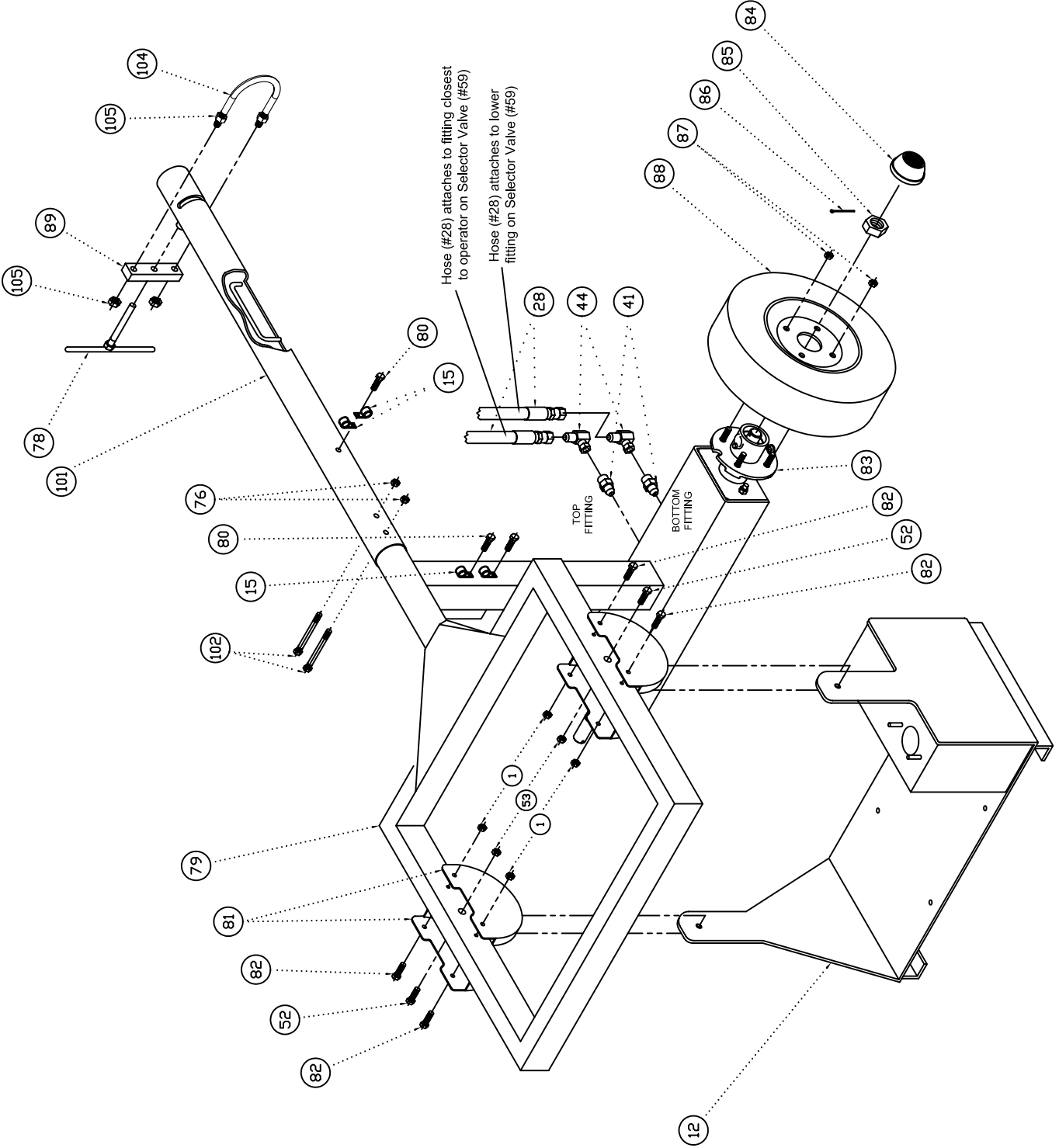

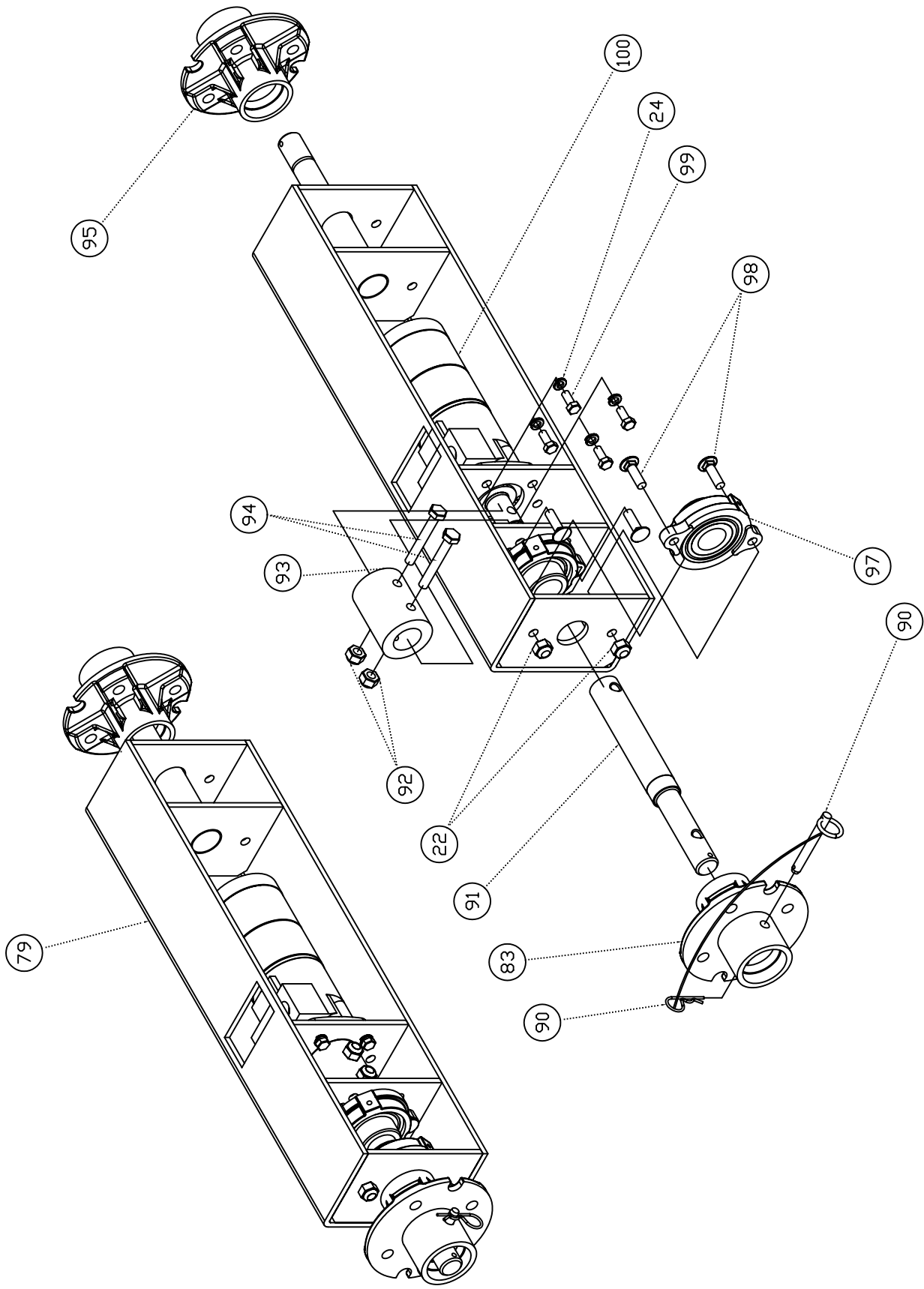

WHEEL DRIVE SYSTEM
SELF-PROPELLED MODELS

850-6001

COMPLETE DRIVE ADAPTER WITH HARDWARE

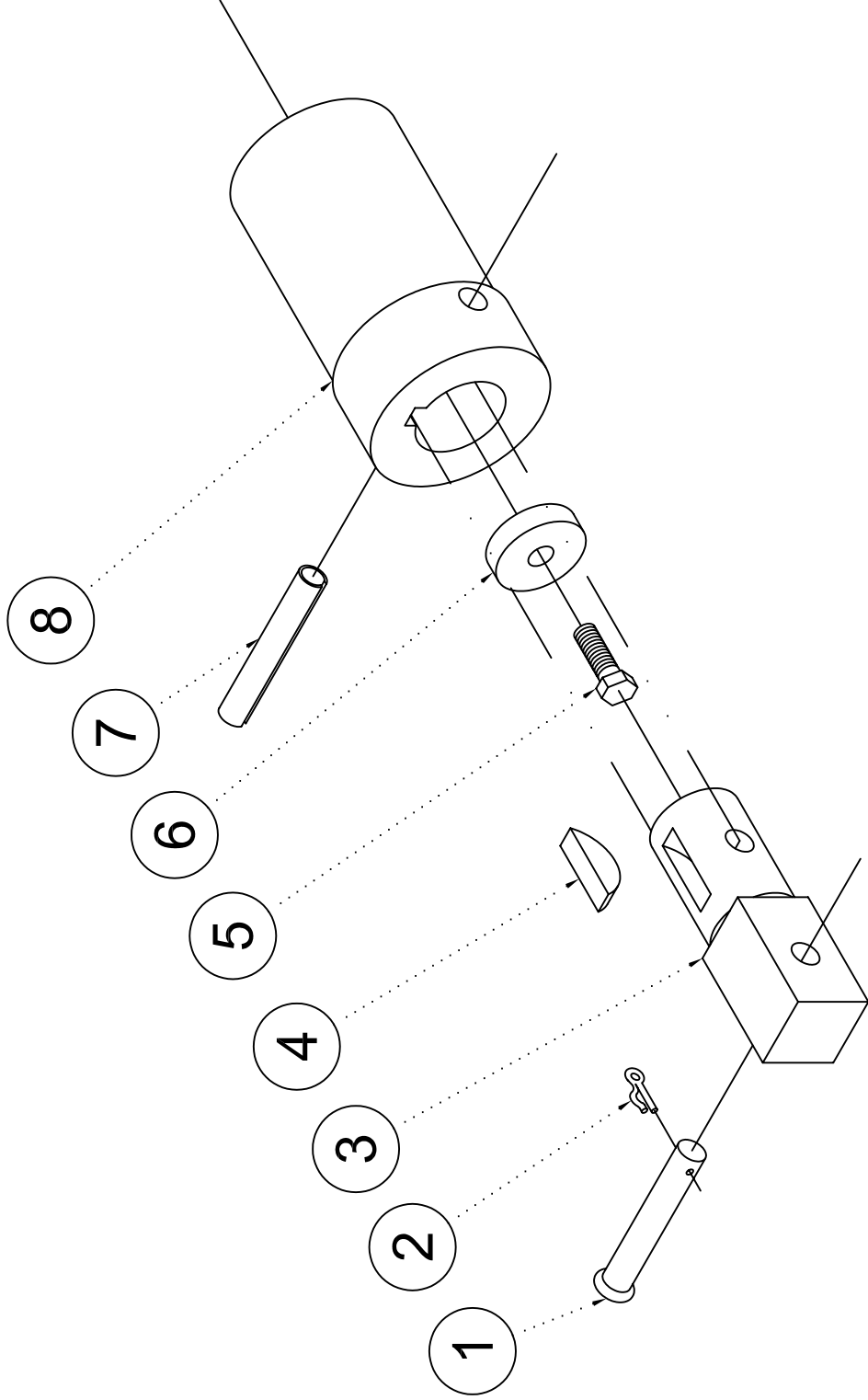

ITEM #	PART #	QTY	DESCRIPTION	FUNCTION
1	090-0655	1	1/4 X 1-7/8" CLEVIS PIN	HOLDS AUGER BIT TO ADAPTER SHAFT
2	090-0656	1	WW 213 HAIR PIN	HOLDS AUGER BIT TO ADAPTER SHAFT
3	850-2502	1	ADAPTER SHAFT	CONNECTS MOTOR AND AUGER BIT
4	080-0086	1	#15 WOODRUFF KEY	HOLDS ADAPTER SHAFT TO ADAPTER BODY
5	090-0060	1	1/4-20 X 1" HHCS	HOLDS ADAPTER BODY TO MOTOR
6	850-2500	1	ADAPTER WASHER	HOLDS ADAPTER BODY TO MOTOR
7	090-0649	1	5/16 X 2" ROLL PIN	HOLDS ADAPTER SHAFT TO ADAPTER BODY
8	850-2503	1	ADAPTER BODY	ATTACHES TO MOTOR

SELF PROPELLED

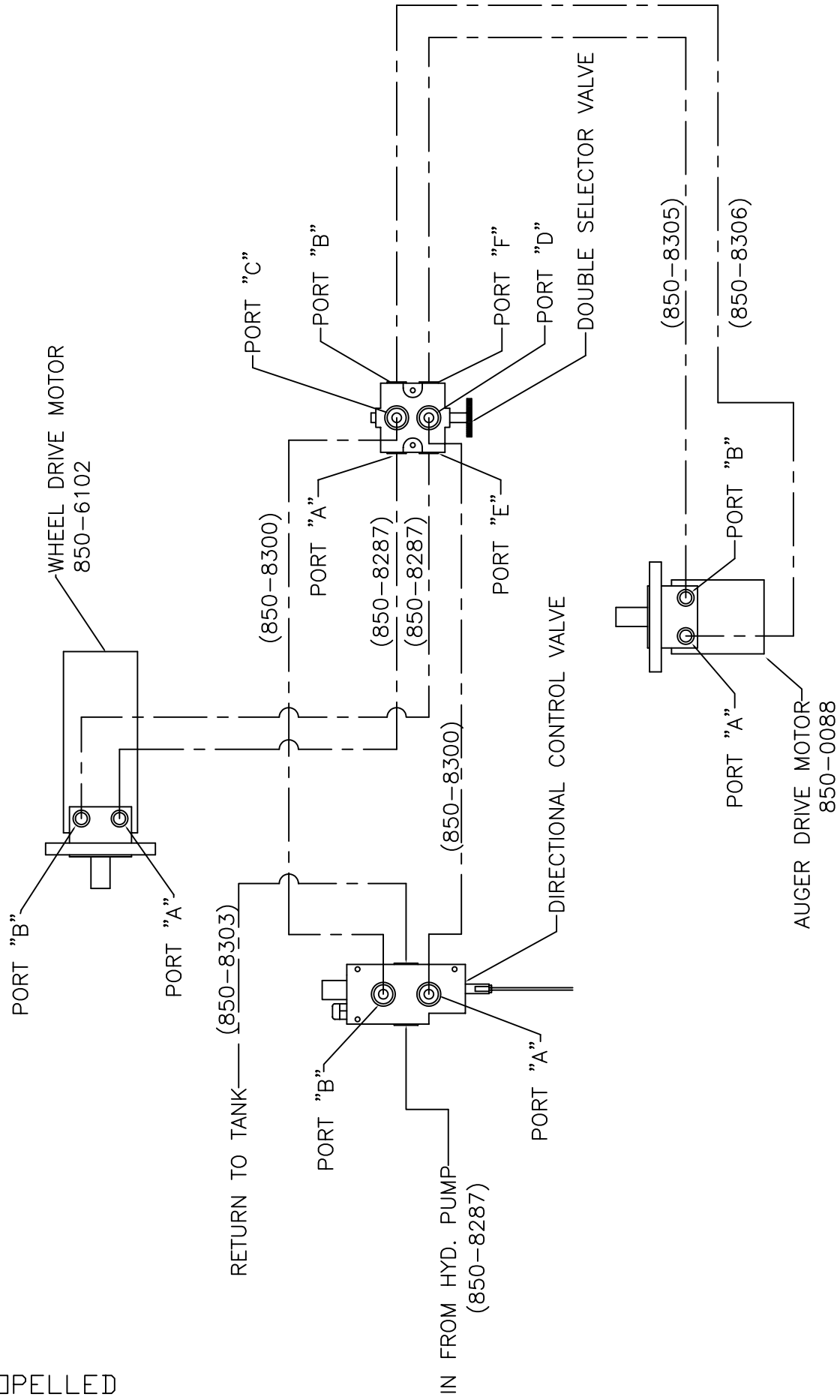

HOSE ROUTING FOR SELF-PROPELLED EASY AUGER

HITCH KIT - 850-0011

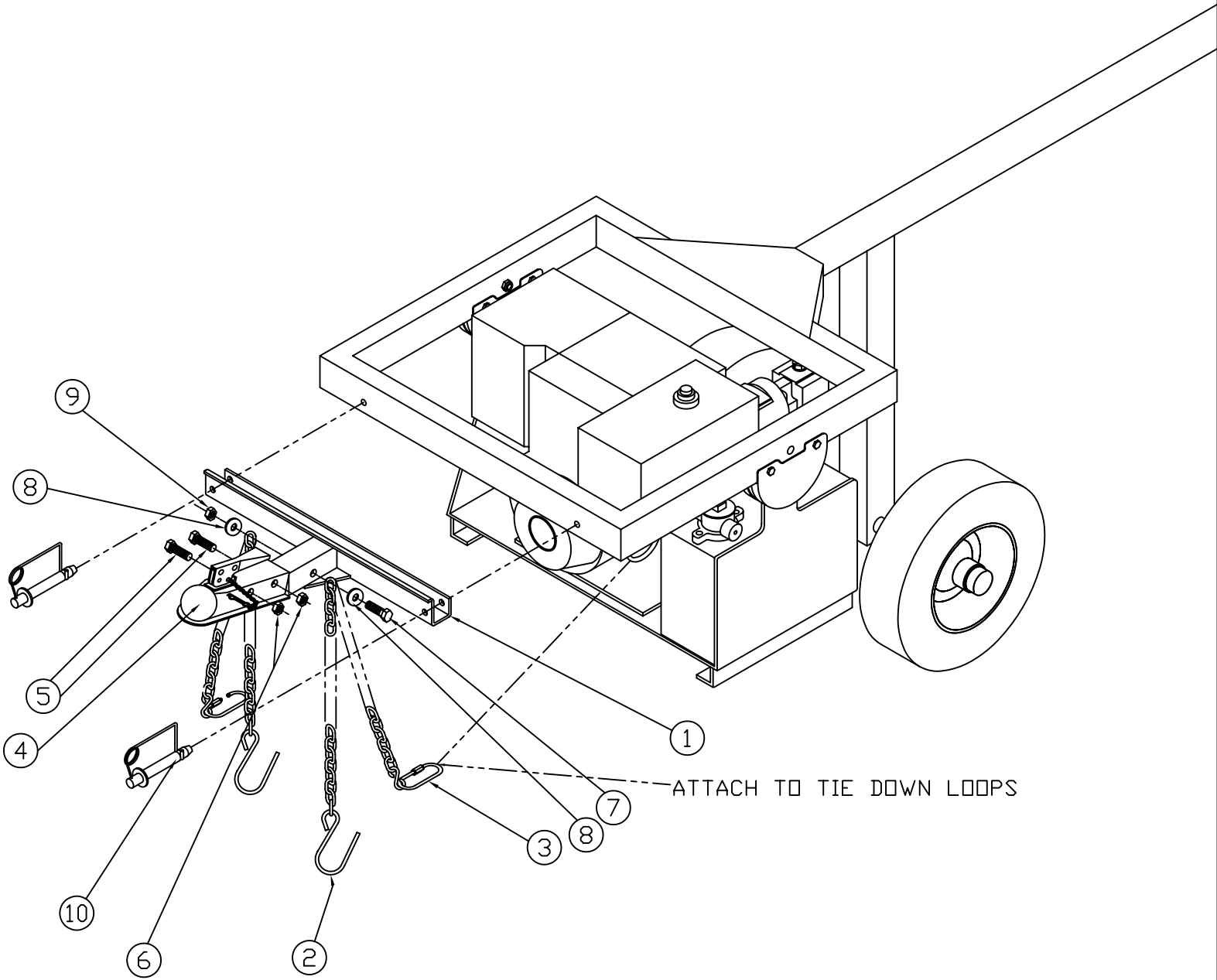

BILL OF MATERIAL

ITEM	QTY	PART NO.	DESCRIPTION
1	1	850-0012	HITCH WELDMENT
2	2	850-0016	4' CLS 1 SFTY CHAIN W/1 S HOOK
3	2	850-0017	3/16 SPRING HOOK
4	1	913-0218	TRAILER HITCH
5	2	090-0370	1/2-13 X 3 HHCS GR5 PLTD
6	2	090-0050	1/2-13 GRIPCO LOCKNUT GR B PLT
7	1	090-0685	3/8-16 X 4 HHCS GR 5 PLTD
8	2	090-0234	3/8 USS FLATWASHER PLTD
9	1	090-0461	3/8-16 NYLON INSERT LOCKNUT
10	2	090-0549	RING PIN & LANYARD

030-0494 AUGER FILTER

030-0494
COMPLETE RETURN
FILTER

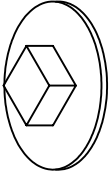
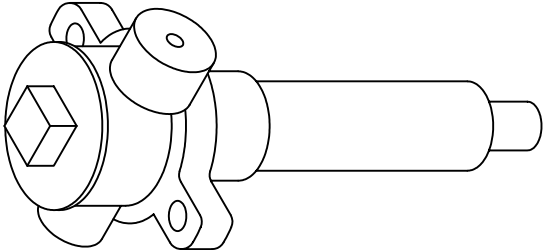

030-0495 - FILTER ELEMENT

030-0496 - BREATHER

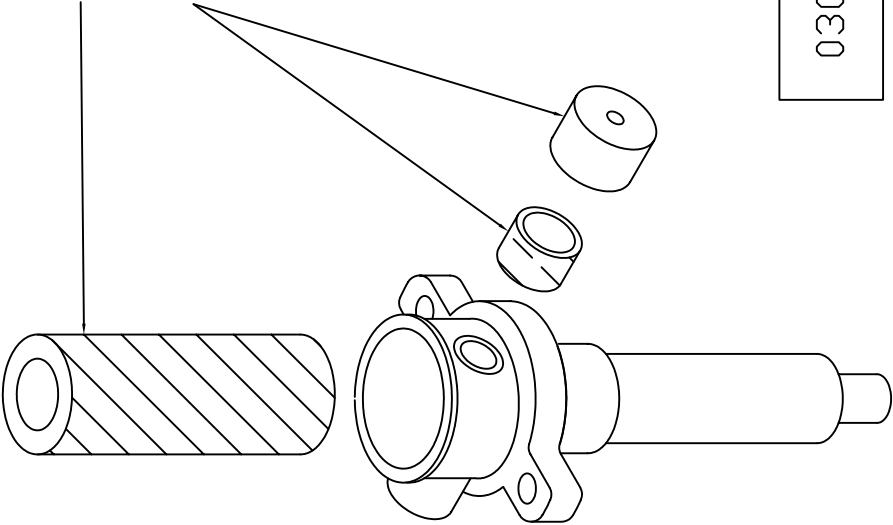

030-0497 - SEAL KIT

OPERATING CONTROL LEVER

ENGINE SAFETY ON-OFF SWITCH

AUGER MOTOR LOCKING PIN

AUGER HEAD LOCKING CLAMP

6 WAY SELECTOR VALVE

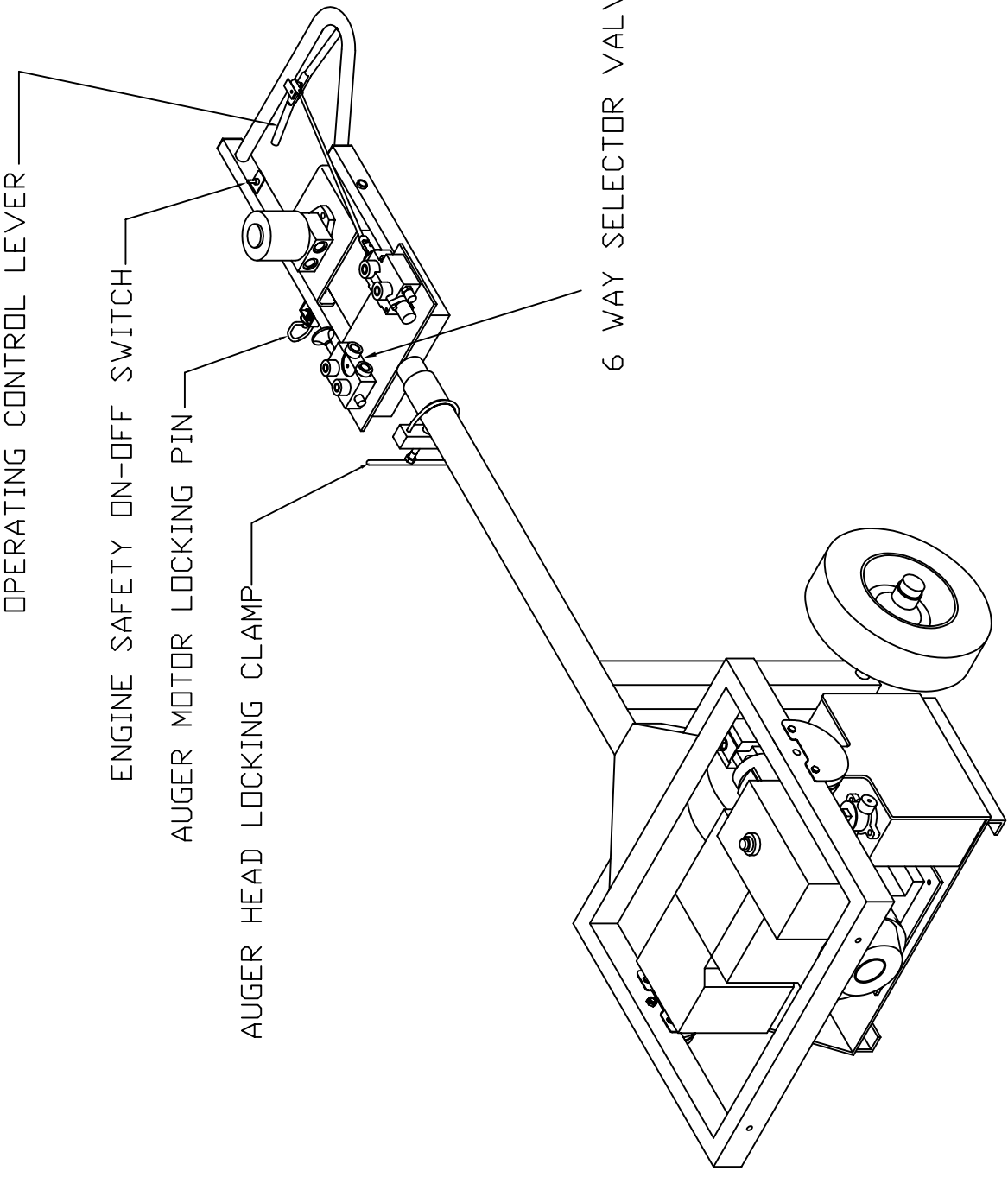

OPERATING CONTROL LEVER POSITIONS

OPERATOR
END

ENGINE
END

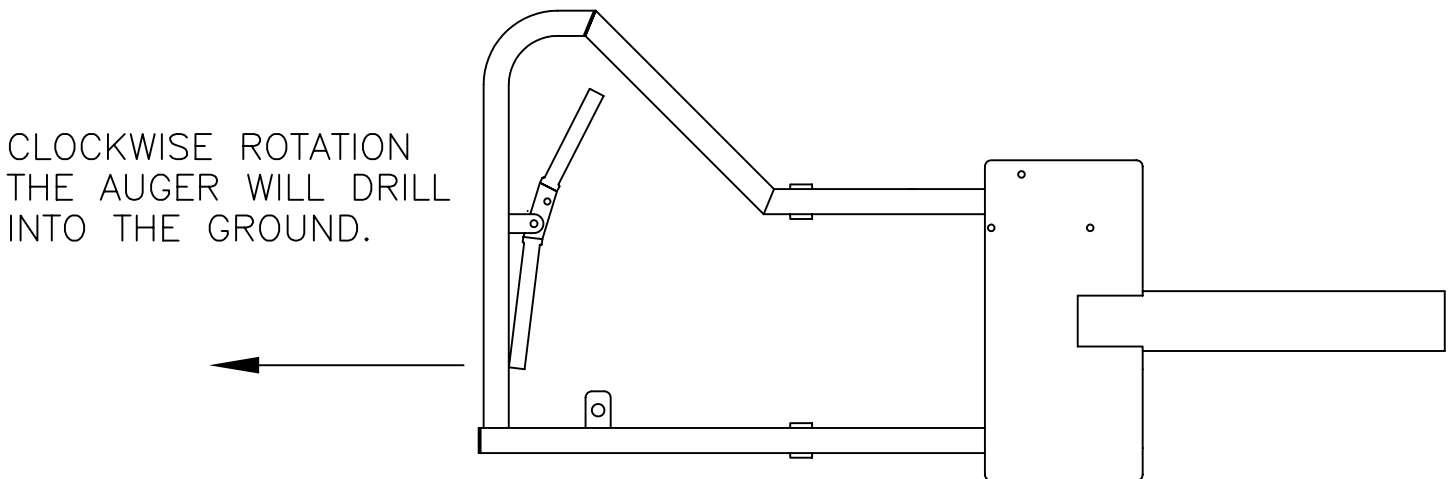
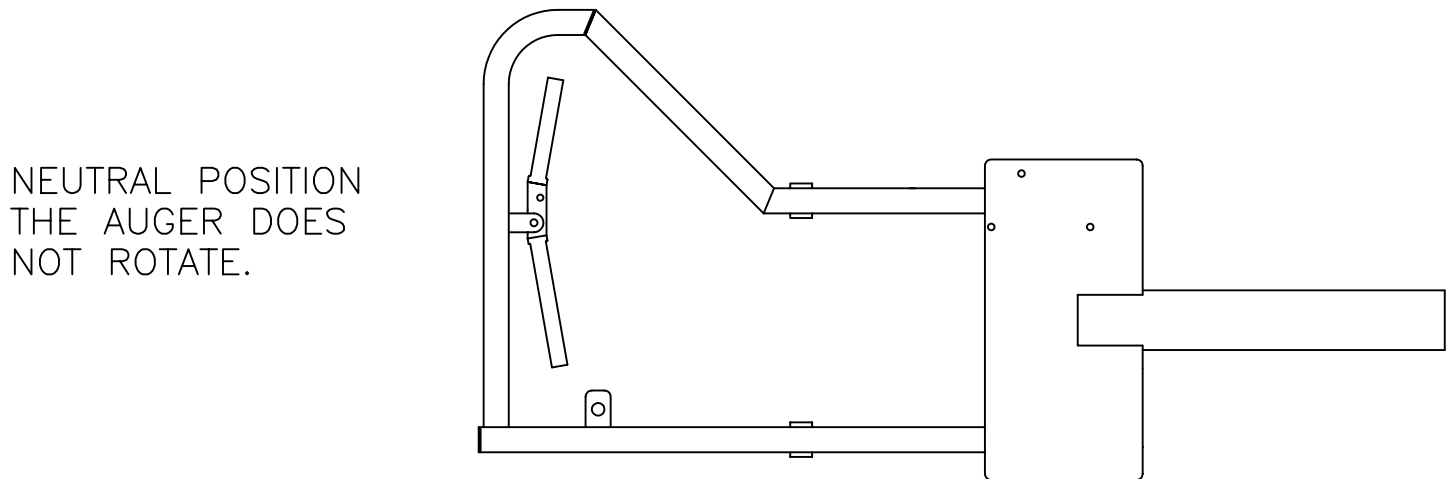
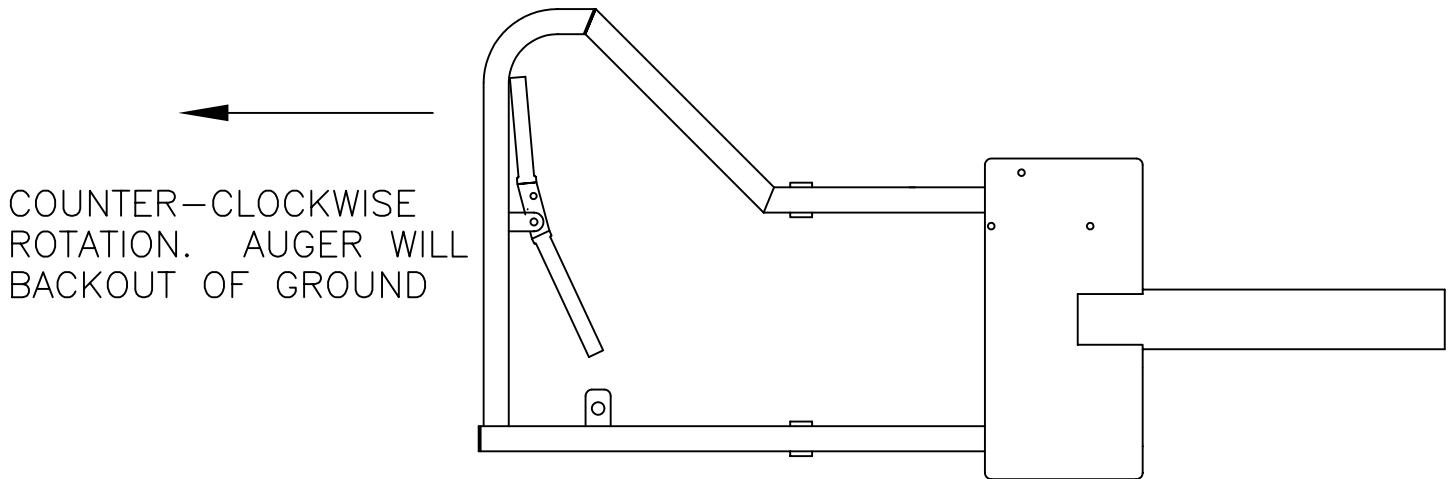

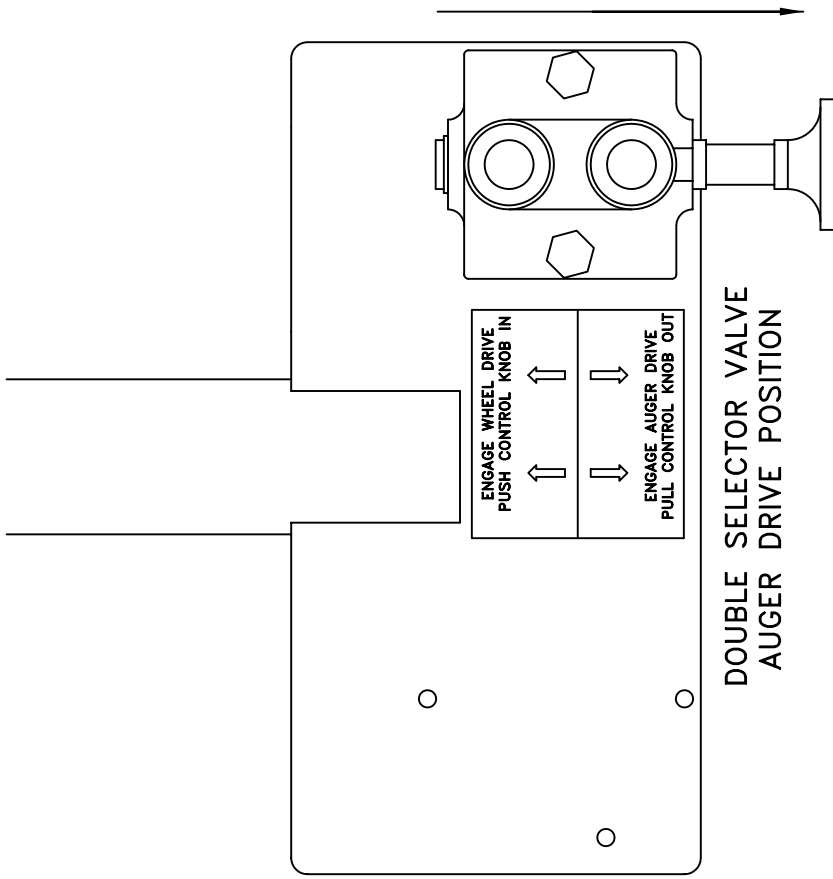

DOUBLE SELECTOR VALVE
AUGER DRIVE POSITION

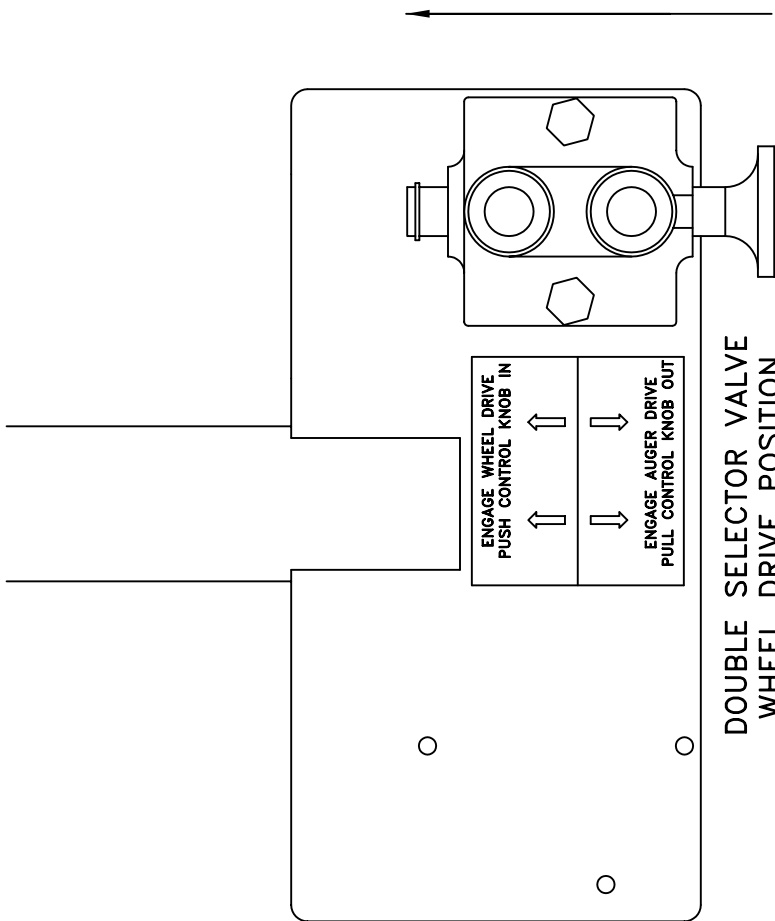

DOUBLE SELECTOR VALVE
WHEEL DRIVE POSITION

OPERATOR POSITION

SELECTOR VALVE

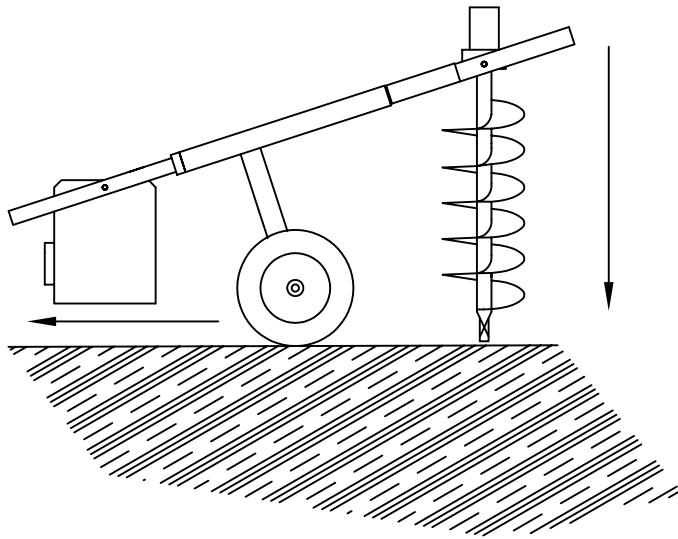

THE EASY AUGER WHEELS MUST BE FREE TO MOVE FORWARD OR OR BACKWARD WHEN DRILLING A HOLE. AS THE AUGER ENTERS THE GROUND THE DISTANCE BETWEEN THE AUGER WHEELS AND THE HOLE WILL CHANGE. THE OPERATOR MUST MOVE THE MACHINE IN ORDER TO DRILL A VERITCAL HOLE.

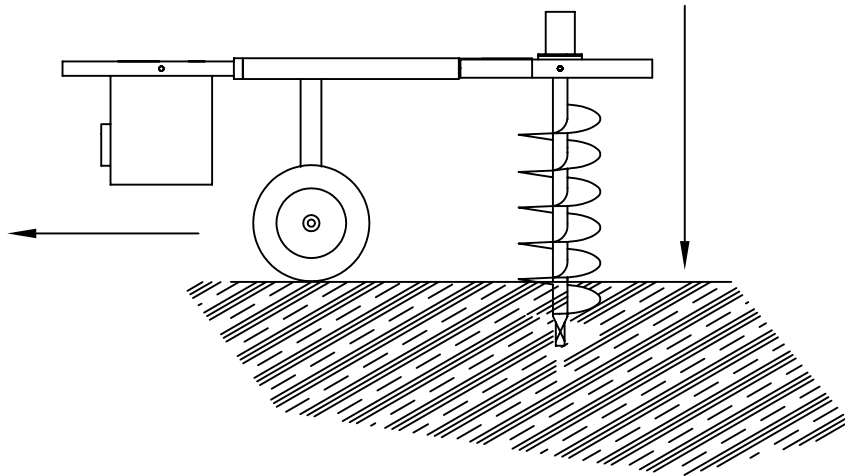

AS YOU CAN SEE BY THIS ILLUSTRATION THE DISTANCE BETWEEN THE AUGER AND THE WHEELS CHANGES THE DEEPER THE HOLE IS DRILLED. THE MACHINE HAS BE PUSHED FORWARD IN ORDER FOR THE HOLE TO BE DRILLED VERITCALLY.

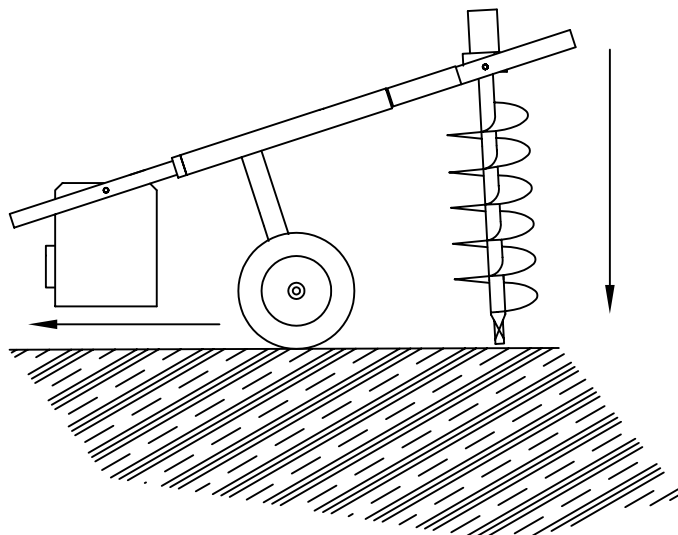

START A HOLE WITH THE AUGER ANGLD SLGHTLY TO THE REAR THE MACHINE WILL HAVE TO BE ADJUSTED TOWARDS THE REAR INITIALLY BUT THEN FORWARD TO COMPLETE THE HOLE. IT WILL MINIMIZE THE TOTAL AMOUNT OF TRAVEL FORWARD REQUIRED.

APPENDIX A

Before you dig call your local one-call center.

ALABAMA

Alabama Line Location Center Inc. 1-800-292-8525 M - F 0700 - 1700

ALASKA

Locate Call Center of Alaska Inc. 1-800-478-3121 M - F 0800 - 1700

ARIZONA

1-800-782-5348

Press 1 for Tucson Blue Stake Center M - F 0700 – 1630

Press 2 for Arizona Blue Stake Inc. M - F 0600 - 1630

ARKANSAS

Arkansas One Call System, Inc. 1-800-482-8998 M - F 0600 - 2100

CALIFORNIA

Underground Service Alert North

Underground Service Alert South 1-800-227-2600 M - F 0600 - 1700

COLORADO

Utility Notification Center of CO. 1-800-922-1987 M - F 0700 - 1700

CONNECTICUT

Call Before You Dig 1-800-922-4455 24 Hours

DELAWARE

Miss Utility of Delmarva 1-800-282-8555 M - F 0700 - 1700

DISTRICT OF COLUMBIA

Miss Utility 1-800-257-7777 M - F 0700 - 1700

FLORIDA

Call Sunshine 1-800-432-4770 M - F 0700 - 1700

GEORGIA

Utilities Protection Center, Inc. 1-800-282-7411 M - F 0700 – 1800

IDAHO

Palouse Empire Underground Coord.	1-800-822-1974	M - F 0730 - 1700
Utilities Underground Location Center	1-800-424-5555	M - F 0600 - 1700
Kootenai County Utility Coord. Council	1-800-428-4950	24 Hours
Shoshone County One Call	1-800-398-3285	24 Hours
Dig Line	1-800-342-1585	24 Hours
One Call Concepts - Idaho	1-800-626-4950	M - F 0500 - 1700

ILLINOIS

Julie, Inc.	1-800-892-0123	24 Hours
Digger (Chicago Utility Alert Network)	1-312-744-7000	24 Hours

INDIANA

Indiana Underground Plant Protect Ser.	1-800-382-5544	24 Hours
--	----------------	----------

IOWA

Underground Plant Location Service	1-800-292-8989	24 Hours
------------------------------------	----------------	----------

KANSAS

Kansas One-Call Center	1-800-344-7233	M - F 0700 - 1800
------------------------	----------------	-------------------

KENTUCKY

Kentucky Underground Protection Ser.	1-800-752-6007	M - F 0700 - 1800
--------------------------------------	----------------	-------------------

MAINE

	1-888-DIG-SAFE	24 Hours
--	----------------	----------

MARYLAND

Miss Utility	1-800-257-7777	M - F 0700 - 1700
Miss Utility of Delmarva	1-800-282-8555	M - F 0700 - 1700

MASSACHUSETTS

	1-888-DIG-SAFE	24 Hours
--	----------------	----------

MICHIGAN

Miss Dig System, Inc.	1-800-482-7171	24 Hours
-----------------------	----------------	----------

MINNESOTA

Gopher State One Call	1-800-252-1166	24 Hours
-----------------------	----------------	----------

MISSISSIPPI

Mississippi One-Call System Inc.	1-800-227-6477	M - F 0730 - 1700
----------------------------------	----------------	-------------------

MISSOURI		
Missouri One Call System Inc.	1-800-344-7483	24 Hours
MONTANA		
Utilities Underground Location Center	1-800-424-5555	M - F 0700 - 1800
Montana One Call Center	1-800-551-8344	24 Hours
NEBRASKA		
Diggers Hotline of Nebraska	1-800-331-5666	24 Hours
NEVADA		
Underground Service Alert North	1-800-227-2600	M - F 0600 - 1900
NEW HAMPSHIRE		
	1-888-DIG-SAFE	24 Hours
NEW JERSEY		
New Jersey One Call	1-800-272-1000	M - F 0600 - 1900
NEW MEXICO		
New Mexico One Call System Inc.	1-800-321-25378	M - F 0700 - 1700
Las Cruces-Dona Utility Council	1-505-526-0400	M - F 0700 - 1600
NEW YORK		
Underground Facilities Protective Org.	1-800-962-7962	M - F 0700 - 1700
Long Island One Call Center	1-800-272-4480	M - F 0700 - 1700
NORTH CAROLINA		
North Carolina One Call Center Inc.	1-800-632-4949	M - F 0700 - 1900
NORTH DAKOTA		
Utilities Underground Location Center	1-800-795-0555	M - F 0800 - 1900
OHIO		
Ohio Utilities Protection Service	1-800-362-2764	24 Hours
OKLAHOMA		
Call Okie	1-800-522-6543	
		M - F 0700 - 1800 Mar - Oct
		M - F 0730 - 1700 Nov - Feb

OREGON

Utilities Underground Location Center	1-800-424-5555	M - F 0600 - 1700
Oregon Utility Notification Center	1-800-332-2344	M - F 0700 - 1700

PENNSYLVANIA

Pennsylvania One Call System, Inc.	1-800-242-1776	24 Hours
------------------------------------	----------------	----------

RHODE ISLAND

	1-888-DIG-SAFE	24 HOURS
--	----------------	----------

SOUTH CAROLINA

Palmetto Utility Protection Service, Inc.	1-800-922-0983	M - F 0730 - 1700
---	----------------	-------------------

SOUTH DAKOTA

South Dakota One Call	1-800-781-7474	24 Hours
-----------------------	----------------	----------

TENNESSEE

Tennessee One-Call System, Inc.	1-800-351-1111	24 Hours
---------------------------------	----------------	----------

TEXAS

Texas One-Call System	1-800-245-4545	24 Hours
-----------------------	----------------	----------

Texas Excavation Safety System	1-800-344-8377	24 Hours
--------------------------------	----------------	----------

Lone Star Notification Center	1-800-669-8344	24 Hours
-------------------------------	----------------	----------

UTAH

Blue Stakes Location Center	1-800-662-4111	M - F 0700 - 1700
-----------------------------	----------------	-------------------

VERMONT

	1-888-DIG-SAFE	24 HOURS
--	----------------	----------

VIRGINIA

Miss Utility of Virginia	1-800-552-7001	M - F 0700 - 1700
--------------------------	----------------	-------------------

Miss Utility	1-800-257-7777	M - F 0700 - 1700
--------------	----------------	-------------------

Miss Utility of Delmarva	1-800-441-8355	M - F 0700 - 1700
--------------------------	----------------	-------------------

WASHINGTON

Utilities Underground Location Center	1-800-424-5555	M - F 0600 - 1700
---------------------------------------	----------------	-------------------

Utilities Cncl. Of Cowlitz County	1-360-425-2506	24 Hours
-----------------------------------	----------------	----------

Chelan-Douglas Util. Coord. Cncl.	1-800-424-5555	24 Hours
-----------------------------------	----------------	----------

Upper Yakima Co. Undgrd. Util. Cncl.	1-800-553-4344	
--------------------------------------	----------------	--

Inland Empire Util. Coord. Cncl.	1-509-456-8000	24 Hours
----------------------------------	----------------	----------

Palouse Empire Util. Coord. Cncl.	1-800-822-1974	M - F 0700 - 1700
-----------------------------------	----------------	-------------------

Utilities Notification Center	1-800-332-2344	M - F 0700 - 1700
-------------------------------	----------------	-------------------

WEST VIRGINIA

Miss Utility of West Virginia, Inc.

1-800-245-4848 24 Hours

WISCONSIN

1-888-DIG-SAFE 24 HOURS

WYOMING

Call-In Dig-In Safety Council

1-800-300-9811 24 Hours

Central Wyoming Util Coord. Cncl.

1-800-759-8035 24 Hours

Southwest Wyoming One-Call

1-307-362-8888 24 Hours

Wyoming One-Call

1-800-348-1030 M - F 0700 - 1700

PART #	APPLICATION
850-1140	Ordinary digging
850-1141	Abrasive soil, impact
850-1405	Compact rock, abrasive soil, NO impact
850-1356	Abrasive frozen soil
850-1196	Abrasive frozen soil, more aggressive than above
850-1142	Ordinary digging, with wear gauge
850-1143	Abrasive soil, impact, with wear gauge
850-1198	Loose rock, compact soil
850-1199	Compact rock, high impact
850-1201	Compact rock, abrasive soil, NO impact
850-1197	Abrasive frozen soil, more aggressive than above



PILOT BITS AND APPLICATION

PART #	TYPE	APPLICATION
850-1100	#SB25 2.5" Dirt	Ordinary digging
850-1103	#SB25HF 2.5" Hardfaced	Abrasive soil impact
850-1101	#SB25C 2.5" Carbide Tipped	Fracturable rock, abrasive soil. No impact.
850-1102	#SB25CXC 2.5" Carbide	Compacted rock abrasion. No impact
850-1104	#SB25HFTC 2.5" Carbide Hardfaced	Compacted rock abrasion. No impact
850-1105	#SB30 3" Dirt	Ordinary digging
850-1108	#SB30HF 3" Hardfaced	Abrasive soil impact
850-1107	#SB30C 3" Carbide	Compacted rock abrasion. No impact
850-1109	#SB30HFTC 3" Carbide Hardfaced	Compacted rock abrasion. No impact
850-1106	#SB35C 3.5" Carbide Tipped	Fracturable rock, abrasive soil. No impact.
850-1110	#SB45 4.5" Dirt	Ordinary digging
850-1113	#SB45HF 4.5" Hardfaced	Abrasive soil impact
850-1111	#SB45C 4.5" Carbide Tipped	Fracturable rock, abrasive soil. No impact.
850-1112	#SB45CXC 4.5" Carbide	Compacted rock abrasion. No impact
850-1114	#SB45HFTC 4.5" Carbide Hardfaced	Compacted rock abrasion. No impact

WARRANTY

Any product manufactured by MacKissic, Inc. and found, in the judgment of MacKissic, Inc., to be defective in material or workmanship, will be repaired or replaced by an Authorized MacKissic Service Dealer without charge for parts and labor to the original owner of the MacKissic product.

The MacKissic product including any defective part must be returned to an Authorized MacKissic Service Dealer within the warranty period. The expense of delivering the product to the dealer for warranty work and the expense of returning it back to the owner after repair or replacement will be borne by the owner. MacKissic's responsibility is limited to making the required repairs or replacements only. No claim of breach of warranty shall be cause for cancellation or rescission of the sales contract of any MacKissic product. Proof of purchase will be required by the dealer to substantiate any warranty claim. All warranty work must be performed by an Authorized MacKissic Service Dealer.

This warranty is limited two years consumer or residential use and 90 days rental or commercial use.

This warranty does not cover any product that has been subject to misuse, abuse, neglect, negligence, or accident, or that has been operated in any way contrary to or inconsistent with the operating instructions as specified in the owner's manual. The warranty does not apply to any damage to the product that is the result of improper maintenance, or to any product or parts that have not been assembled or installed as specified in the owner's manual.

The warranty does not cover any product that has been altered or modified. In addition, the warranty does not extend to repairs made necessary by normal wear, or by the use of parts or accessories which, in the judgment of MacKissic, Inc., are either incompatible with the MacKissic product or adversely affect its operation, performance or durability. This warranty does not cover engines, electric starters, batteries, and tires, which are warranted separately by their manufacturer and for a different period of time.

MacKissic, Inc. reserves the right to change the design of any product without assuming any obligation to modify any product previously manufactured.

THE DURATION OF THE LIMITED WARRANTY IS ONE YEAR COMMERCIAL AND RENTAL USE. REPAIR OR REPLACEMENT AS PROCEEDED UNDER THIS LIMITED WARRANTY IS THE EXCLUSIVE REMEDY OF THE PURCHASER. MacKissic, Inc. SHALL NOT BE LIABLE FOR ANY INCIDENTAL OR CONSEQUENTIAL DAMAGES EXCEPT THE LIMITED WARRANTY DESCRIBED ABOVE; ALL IMPLIED WARRANTIES (MERCHANTABILITY AND FITNESS FOR A PARTICULAR PURPOSE) ARE SPECIFICALLY DISCLAIMED.

MacKissic, Inc. ASSUMES NO RESPONSIBILITY FOR INCIDENTAL, CONSEQUENTIAL OR OTHER DAMAGES INCLUDING, BUT NOT LIMITED TO, EXPENSE FOR GASOLINE, OIL, EXPENSE OF DELIVERING THE PRODUCT TO AN AUTHORIZED MacKissic SERVICE DEALER AND EXPENSE OF RETURNING IT BACK TO THE OWNER, MECHANIC'S TRAVEL TIME, TELEPHONE OR TELEGRAM CHARGES, RENTAL OF A LIKE PRODUCT DURING THE TIME WARRANTY REPAIRS ARE BEING PERFORMED, TRAVEL, LOSS OR DAMAGE TO PERSONAL PROPERTY, LOSS OF REVENUE, LOSS OF USE OF THE PRODUCT, LOSS OF TIME OR INCONVENIENCE.

This warranty gives you specific legal rights, and you may also have other rights that vary from state to state.

04/30/07