

# OPERATING INSTRUCTIONS AND PARTS LIST INSTRUCCIONES DE OPERACIÓN Y LISTA DE PIEZAS



## MC18 Concrete Saw

**MODELS:** MC1809R (9 HP ROBIN)  
MC1809H (9 HP HONDA)  
MC1813R (13.5 HP ROBIN)  
MC1813H (13 HP HONDA)  
MC1805G (5 HP GAST)  
MC1805B (5 HP BALDOR)

**Model:** \_\_\_\_\_

**Serial Number:** \_\_\_\_\_

**Engine Serial No.:** \_\_\_\_\_

**Purchase Date:** \_\_\_\_\_

0A7859  
Copyright © July 11, 2002 DBInc.  
Printed in U.S.A.



17400 West 119th Street  
Olathe, Kansas 66061

Customer Service ..... 800-288-5040  
Corp. Office ..... 913-928-1000  
Cust. Service FAX .... 800-825-0028  
Corp. Office FAX ..... 913-438-7951  
Int'l. FAX ..... 913-438-7938

**Internet** [www.targetblue.com](http://www.targetblue.com)



**EVERY MACHINE IS THOROUGHLY TESTED BEFORE LEAVING THE FACTORY. EACH MACHINE IS SUPPLIED WITH A COPY OF THIS MANUAL. OPERATORS OF THIS EQUIPMENT MUST READ AND BE FAMILIAR WITH THE SAFETY WARNINGS. FAILURE TO OBEY WARNINGS MAY RESULT IN INJURY OR DEATH. FOLLOW INSTRUCTIONS STRICTLY TO ENSURE LONG SERVICE IN NORMAL OPERATION.**

## **CONTENTS**

Symbol Definitions .....	4 - 6
Decal Descriptions and Locations .....	7
Saw Configurations and Models / Power Source / Dimensions .....	9
Safety Warnings - DO's & DO NOT's .....	10 - 11
Reference Figures .....	12
Pre-Operation Checklist / Maintenance Schedule .....	13
Instructions:	
1. Features .....	14
2. Assembly .....	14
3. General Instructions .....	14
4. Check Before Starting .....	15
5. Fitting the Blade .....	15
6. Starting the Power Source .....	15
7. Maneuver the Saw .....	16
8. To Start Sawing .....	16
9. Stopping the Saw .....	16
10. Maintenance Instructions .....	17
11. Optional And Accessory (Field Installed) .....	17
12. Governor Speed .....	18
13. Repairs .....	18
14. Service Parts .....	18
Parts List Diagrams:	
Diagram 1 - Frame & Axle .....	20, 21
Diagram 2 - Depth Control (Screw Feed) .....	22, 23
Diagram 3 - Depth Control (Lock Bar) .....	24, 25
Diagram 4 - Pointer & Belt Guard .....	26, 27
Diagram 5 - Guards & Water Distribution .....	28, 29
Diagram 6 - Blade Guard .....	30, 31
Diagram 7 - Engine & Bladeshaft .....	32, 33
Diagram 8 - Electric Motor .....	34, 35
Diagram 9 - Air Motor .....	36, 37
Diagram 10 - Kit, Water Tank (174957) .....	38

**NOTE:**  
**NOTA:**



# Symbol Definitions

## Definición De Simbolos

---



- Please Read The Instructions For Use Prior To Operating The Machine For The First Time.
- Antes De La Puesta En Marcha, Lea Detenidamente Las Instrucciones Y Familiarícese Con La Máquina.



- Mandatory
- Obligatorio



- Indication
- Indicación



- Prohibition
- Prohibición



- Warning Triangle
- Triángulo De Advertencia



- Wear Eye Protection
- Usar Gafas De Protección



- Wear Head Protection
- Usar Casco De Protección



- Wear Breathing Protection
- Usar Máscara De Protección



- The Use Of Ear Protection Is Mandatory
- Es Obligatorio El Uso De Protección Auditiva



- Wear a Hard Hat
- Usar Casco Duro



- Wear Safety Shoes
- Usar Zapatos De Seguridad



- Wear Appropriate Clothing
- Usar Ropa Adecuada



- Remove The Blade Prior To Hoisting, Loading, Unloading And Transporting The Machine On Jobsite
- Desmontar El Disco Antes De Desplazar, Cargar, Descargar O Transportar La Máquina En La Obra



- Motor Off
- Parar El Motor



- Use In Well Ventilated Area
- Usar En Una Área Bien Ventilada



- Do Not Use In Flammable Areas
- No Usar In Áreas Inflamables



- Machinery Hazard, Keep Hands And Feet Clear
- Máquina Peligrosa - Mantenga Manos Y Pies Alejados De La Máquina



- Danger, Poison Exhaust Gas
- Peligro, Gas De Escape Venenoso



- No Non-working Personnel In Area
- Prohibido Para Personas Ajenas A La Obra



- No Smoking
- No Fumar



- Do Not Operate Without All Guards In Place
- No Operar Sin Todas Las Protecciones In Su Sitio



- Always Keep the Blade Guards In Place
- Mantenga Siempre Las Protecciones De La Hoja En Su Sitio



- Water Supply On
- Suministro De Agua Desconectado



- Water Supply Off
- Suministro De Agua Des Conectado



- Keep Work Area Clean/Well Lit, Remove All Safety Hazards
- Mantenga Limpio El Sitio De Trabajo/Bien Iluminado, Elimine Todos Los Riesgos De Seguridad



- Dangerously High Noise Level
- Nivel De Ruido Elevadamente Peligroso



- Pay Extreme Attention To The Care And Protection Of The Machine Before Starting Up
- Ponga Extrema Atención Al Cuidado Y Preparación De La Máquina Antes De Ponerla En Marcha



- Remove Tools From Area And Machine
- Elimine Las Herramientas Del Área Y De La Máquina



- Oil Required
- Necesita Aceita



- Dipstick, Maintain Proper Oil Level
- Varilla De Control, Mantenga El Nivel De Aceite Correcto



- Lubrication Point
- Punto De Lubrication



- Unleaded Fuel Only
- Combustible Sin Piomo Solamente



- Repairs Are To Be Done By An Authorized Dealer Only
- Las Reparaciones Deben Ser Efectuadas Únicamente Por Un Distribuidor Autorizado



- Diamond Blade
- Sierra Diamantada



- Blade Diameter
- Diámetro De La Hoja

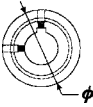

- Pulley Diameter
- Diámetro De La Correa



- Number of Revolutions Per Minute, Rotational Speed
- N° De Revoluciones Por Minuto, Velocidad De Rotación



- Blade Flange Diameter
- Diámetro De La Brida De La Hoja



- Machine Mass (lbs)
- Masa De La Máquina (lbs)



- Electric Motor
- Motor eléctrico



- Engine
- Motor



- Engine Speed Revolutions/Minute
- Velocidad Del Motor En Revoluciones Por Minuto (RPM)



- Engine Start
- Arranque Del Motor

## WARNING

### HEARING HAZARD

DURING NORMAL USE OF THIS MACHINE, OPERATOR MAY BE EXPOSED TO A NOISE LEVEL EQUAL OR SUPERIOR TO **85 dB (A)**

## ATENCIÓN

### RIESGO DE DAÑO AUDITIVO

EN CONDICIONES NORMALES DE UTILIZACIÓN, EL OPERADOR DE ESTA MÁQUINA PUEDE ESTAR EXPUESTO A UN NIVEL DE RUIDO IGUAL O SUPERIOR A **85 dB (A)**

# DECAL DESCRIPTIONS AND LOCATIONS DESCRIPCIÓN DE CALCAMONIAS Y UBICACIONES



P/N 189732  
Location: Front of Frame (All Models)  
Quantity: 1



P/N 189731  
Location: Blade Guard (All Models)  
Quantity: 1



P/N 174993  
Location: Belt Guard (All Models)  
Quantity: 1



P/N 187691  
Location: Frame (All Models)  
Quantity: 1

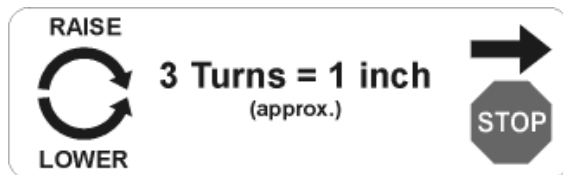

P/N 174998  
Location: Top of Screw Feed Bracket  
(Screw Feed Model Only)  
Quantity: 1

DEPTH OF CUT	450 MM	177	152	127	101	76	50	25	0	MM
	18 INCH	7	6	5	4	3	2	1	0	IN.
	BLADE SIZE									
	14 INCH	5	4	3	2	1	0			IN.
	350 MM	127	101	76	50	25	0			MM

P/N 139633  
Location: Front of Handle Support (E-Z Tilt Model Only)  
Quantity: 1



P/N 177588  
Location: Top of Belt Guard (All Models)  
Quantity: 1



P/N 169065  
Location: Engine Fuel Tank (All Models)  
Quantity 1



P/N 040563  
Location: Front of Frame (All Models)  
Quantity: 1

**NOTE:**  
**NOTA:**

## MC 18 Specifications

Power Source	Gas				Pneumatic	Electric
<b>MC 18 Model</b>	<b>MC 18 9R</b>	<b>MC 18 9H</b>	<b>MC 18 13.5R</b>	<b>MC 18 13H</b>	<b>MC 18 5A</b>	<b>MC 18 5E</b>
<b>Horsepower</b>	9 HP	9 HP	13.5 HP	13 HP	5 HP	5 HP (230 V)
<b>Standard Model</b>	C00094	C00084	C00098	C00086	C00088	C00090
<b>Screw Feed Model</b>	C00095	C00085	C00099	C00087	C00089	C00091

### ALL SAWS FEATURE:

<b>Max. Blade Cap. in. (mm)</b>	18 (450)	18 (450)	18 (450)	18 (450)	18 (450)	18 (450)
<b>Max. Depth of Cut</b>	4-5/8"-6-5/8" (117.5-168.3mm)					
<b>Blade Shaft RPM</b>	2,600	2,600	2,600	2,600	2,500	1,800
<b>Weight Crated - lb. (Kg)</b>	199 (90)	209 (95)	222 (101)	222 (101)	203 (92)	268 (120)
<b>Uncrated - lb. (Kg)</b>	172 (78)	182 (83)	195 (88)	195 (88)	176 (80)	241 (109)
<b>Arbor Size</b>	1" (25.4mm)					
<b>Blade Flange</b>	4-1/2" dia. with drive pin					
<b>Blade Drive</b>	2 V-belts (5-8 HP); 3 V-belts (13 HP engine)					
<b>Blade Control</b>	Spring assisted raise/lower system with single lock down knob or spring assisted screw feed					
<b>Blade Coolant</b>	Removable dual water spray tubes; water supply connector located on left side of saw; control					
<b>Axle Front</b>	3/4" (19 mm) diameter; raises and lowers cutting head					
<b>Wheels Front</b>	5" x 1-1/2" x 3/4" (102 x 38 x 19mm); solid rubber tires, cast iron hub, roller bearings, lube					
<b>Rear</b>	8" x 2" x 5/8" (203 x 51 x 15.9mm); ball bearings; semi-pneumatic tires					
<b>Chassis</b>	One piece reinforced box base					

### POWER SOURCE:

<b>Engine/Motor</b>	Robin Gas Engine	Honda Gas Engine	Robin Gas Engine	Honda Gas Engine	Cast Pneumatic Motor	Baldor Electric Motor, 1 ph
<b>Specifications</b>	EX27	GX270	EH41	GX390	120CFM @90 PSI	208/230V 60 cy/AC
<b>Max. Horsepower</b>	9 HP	9 HP	13.5 HP	13 HP	5 HP	5 HP
<b>Displacement cu. in. (cc)</b>	16.7 (265)	16.5 (270)	24.7 (404)	23.7 (389)		
<b>Bore - in. (mm)</b>	2.95 (75)	3.0 (76)	3.5 (88)	3.5 (88)		21.5/20 - Full Load Amp Rating
<b>Stroke - in. (mm)</b>	2.36 (60)	2.3 (58)	2.6 (65)	2.5 (64)		
<b>Cylinders/Stroke</b>	1/4	1/4	1/4	1/4		
<b>Fuel Capacity - gal. (l)</b>	1.6 (6)	1.59 (6.0)	1.85 (7.0)	1.72 (6.5)		
<b>Oil Capacity - pt. (l)</b>	2.2 (1.1)	2.3 (1.1)	2.5 (1.2)	2.3 (1.1)		
<b>Air Filter</b>	Dry type dual element w/pre cleaner	Dry type dual element w/pre cleaner	Dry type dual element w/pre cleaner	Dry type dual element w/pre		
<b>Starter</b>	Recoil	Recoil	Recoil	Recoil	Valve	Switch
<b>Engine Coolant</b>	Air	Air	Air	Air	Air	Air
<b>Oil Sentry</b>	Standard	Standard	Standard	Standard	N/A	N/A

Accessories	Item No.
Tie Down Kit	<b>167189</b>
Outer Flange (1/2" cutting width)	<b>167963</b>
Replacement Blade Wrench	<b>163988</b>
Water Tank Kit (Standard saw)	<b>174957</b>

### SAW DIMENSIONS: Inches (mm)

Crated Dimensions: L-35" x H-30-1/2" x W-22" (889 x 775 x 559mm)

	Inches	Metric (mm)
A - Height (Max.) - In. (mm)	47-1/2	(1207)
B - Saw Length, Pointer Up	45-1/2	(1156)
C - Max. Saw Length, Pointer	64-1/4	(1632)
E - Pointer Extension	18-3/4	(476)
F - Frame Width	16	(406)
G - Frame Length	22-1/2	(572)
H - Saw Width	22	(559)
I - Front Axle Length	10-1/4	(260)
J - Rear Wheel Track	19-1/2	(495)
K - Blade to Wall	2-3/8	(61)
L - Wheel Base Length	15	(381)

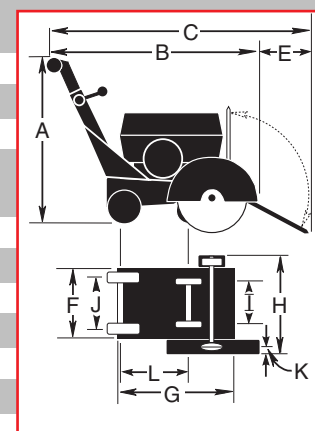

Specifications are subject to change without notice.

# SAFETY FIRST!



**WARNING: FAILURE TO COMPLY WITH THESE WARNINGS AND OPERATING INSTRUCTIONS COULD RESULT IN DEATH OR SERIOUS BODILY INJURY.**

## DO

- DO read this entire operator's manual before operating this machine. Understand all warnings, instructions, and controls.
- DO keep all guards in place and in good condition.
- DO wear safety approved hearing, eye, head and respiratory protection.
- DO read and understand all warnings and instructions on the machine.
- DO read and understand the symbol definitions contained in this manual.
- DO keep all parts of your body away from the blade and all other moving parts.
- DO know how to stop the machine quickly in case of emergency.
- DO turn the "ON/OFF" switch to the "OFF" position prior to connecting the electric powered model to the power source.
- DO inspect the blade, flanges and shafts for damage before installing the blade.
- DO use the blade flange size shown for each blade size.
- DO use only steel center diamond blades manufactured for use on concrete saws.
- DO use only reinforced abrasive blades or steel center diamond blades manufactured for use on concrete saws.
- DO use only the blade flanges supplied with the saw. Never use damaged or worn blade flanges.
- DO use only blades marked with a maximum operating speed greater than the blade shaft speed. Verify speed by checking blade shaft rpm and pulley diameters.
- DO verify saw drive configuration by checking blade shaft RPM, pulley diameters, and blade flange diameter.
- DO read all safety materials and instructions that accompany any blade used with this machine.
- DO inspect each blade carefully before using it. If there are any signs of damage or unusual wear, **DO NOT USE THE BLADE.**
- DO mount the blade solidly and firmly. Wrench tighten the arbor nut.
- DO make sure the blade and flanges are clean and free of dirt and debris before mounting the blade on the saw.
- DO use the correct blade for the type of work being done. Check with blade manufacturer if you do not know if blade is correct.
- DO use caution and follow the instructions when loading and unloading the machine.
- DO operate this machine only in well ventilated areas.
- DO instruct bystanders on where to stand while the machine is in operation.
- DO establish a training program for all operators of this machine.
- DO clear the work area of unnecessary people. Never allow anyone to stand in front of or behind the blade while the engine is running.
- DO make sure the blade is not contacting anything before starting the engine.
- DO use caution when lifting and transporting this machine.
- DO always tie down the machine when transporting.
- DO use caution and follow instructions when setting up or transporting the machine.
- DO have all service performed by competent service personnel.
- DO make sure electric powered machines are plugged into a properly grounded circuit.
- DO make sure power cords are the proper size and in good condition.
- DO verify the blade arbor hole matches the machine spindle before mounting the blade
- DO always check for buried electrical cables before sawing. If unsure, contact the local utilities.
- DO clean the machine after each day's use.
- DO follow all electrical codes in your area.
- DO consider work area environment. Don't expose power tools to rain. Don't use power tools in wet locations.
- DO use caution to guard against electric shock. Prevent body contact with grounded surfaces (i.e., pipes, radiators, ranges, refrigerators).
- DO use correct voltage and proper extension cords. Never carry tool by cord or yank it to disconnect it from receptacle. Keep cord away from heat, oil and sharp edges.
- DO always transport the machine with the motor stopped.
- DO keep the handles dry, clean and free of oil and dirt.
- DO disconnect tools from power source when not in use, before servicing and when changing accessories.
- DO carefully maintain and clean for better and safer performance. Follow instructions for changing accessories. Inspect tool cords periodically and, if damaged, have repaired by authorized service facility.
- DO always give a copy of this manual to the equipment user. If you need extra copies, call TOLL FREE 1-800-288-5040.

## SAFETY FIRST!



**WARNING: FAILURE TO COMPLY WITH THESE WARNINGS AND OPERATING INSTRUCTIONS COULD RESULT IN DEATH OR SERIOUS BODILY INJURY.**

### DO NOT

- DO NOT** operate this machine unless you have read and understood this operator's manual.
- DO NOT** operate this machine without the blade guard, or other protective guards in place.
- DO NOT** stand behind or in front of the blade path while the engine/motor is running.
- DO NOT** leave this machine unattended while the engine/motor is running.
- DO NOT** work on this machine while the engine/motor is running.
- DO NOT** operate this machine when you are tired or fatigued.
- DO NOT** use a wet blade without adequate water supply to the blade.
- DO NOT** exceed maximum blade speed shown for each blade size. Excessive speed could result in blade breakage.
- DO NOT** operate the machine if you are uncertain of how to run the machine.
- DO NOT** use damaged equipment or blades.
- DO NOT** touch or try to stop a moving blade with your hand.
- DO NOT** cock, jam, wedge or twist the blade in a cut.
- DO NOT** transport a cutting machine with the blade mounted on the machine.
- DO NOT** use a blade that has been dropped or damaged.
- DO NOT** use carbide tipped blades.
- DO NOT** touch a dry cutting diamond blade immediately after use. These blades require several minutes to cool after each cut.
- DO NOT** use damaged or worn blade flanges.
- DO NOT** allow other persons to be near the machine when starting, refueling, or when the machine is in operation.
- DO NOT** operate this machine in an enclosed area unless it is properly vented.
- DO NOT** operate this machine in the vicinity of anything that is flammable. Sparks could cause a fire or an explosion.
- DO NOT** allow blade exposure from the guard to be more than 180 degrees.
- DO NOT** operate this machine with the belt guard or blade guard removed.
- DO NOT** operate this machine unless you are specifically trained to do so.
- DO NOT** use a blade that has been over heated. (Core has a bluish color.)
- DO NOT** jam material into the blade.
- DO NOT** grind on the side of the blade.
- DO NOT** lay power cords in or near the water.
- DO NOT** tow this machine behind a vehicle.
- DO NOT** replace the motor with any motor that does not have a special grounding connection.
- DO NOT** operate this machine while under the influence of drugs or alcohol.

\*\*\*\*\*

This saw was designed for certain applications only. **DO NOT** modify this saw or use for any application other than for which it was designed. If you have any questions relative to its application, **DO NOT** use the saw until you have written Diamant Boart, Inc. and we have advised you.

Diamant Boart, Inc.  
17400 West 119th Street  
Olathe, Kansas 66061  
USA

**FIGURE 1**

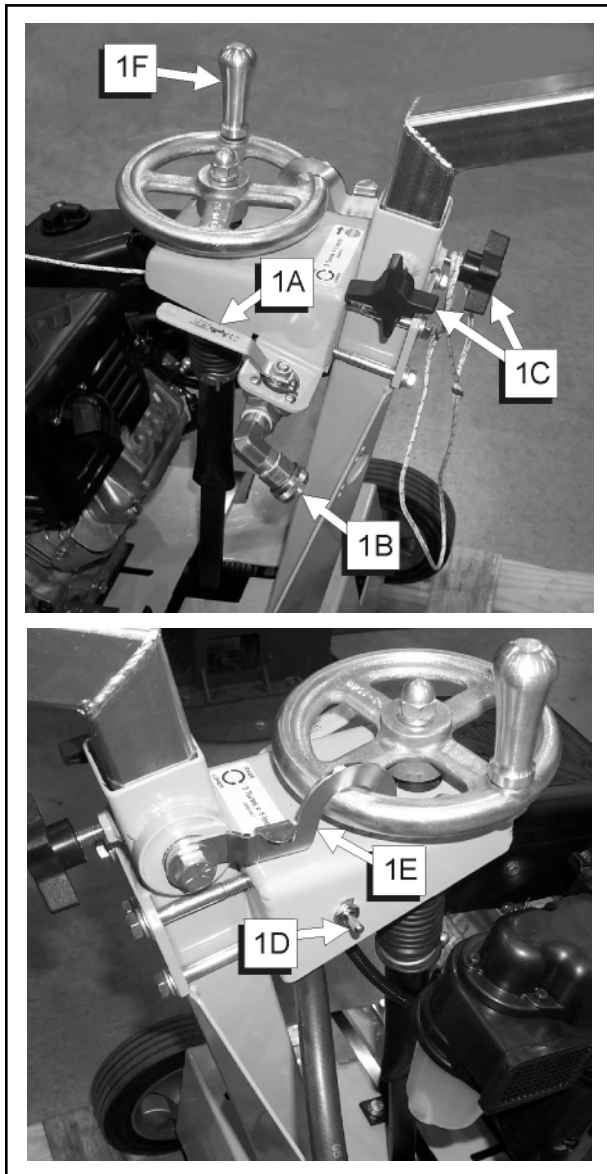

- 1A. WATER VALVE:** Use to control the water supply to the diamond blade.
- 1B. WATER INLET:** Connect water hose at this garden hose connection.
- 1C. HANDLE ADJUSTMENT KNOBS:** Use to adjust handle height.
- 1D. ENGINE STOP SWITCH:** Stop Switch: Push down to stop engine.
- 1E. DEPTH CONTROL LOCK:** Use to lock the position of the Depth Control Hand Wheel.
- 1F. DEPTH CONTROL HAND WHEEL:** Controls lowering and raising of the blade into and out of the

**FIGURE 2**

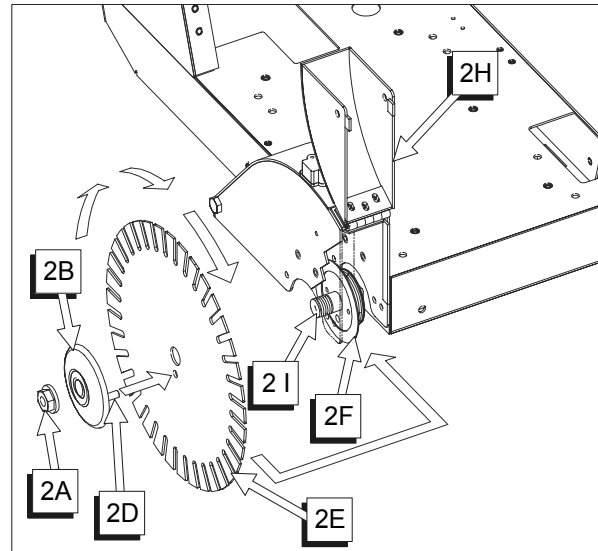

- 2A. BLADE SHAFT NUT:** Use to tighten the outer flange against the diamond blade.
- 2B. OUTER FLANGE:** Use to hold the diamond blade in position.
- 2C. NOT USED**
- 2D. LOCKING PIN:** Use to prevent the diamond blade from rotating on the shaft during operation.
- 2E. DIAMOND BLADE:** Use as the cutting tool for concrete and asphalt surfaces.
- 2F. INNER FLANGE:** Inside support used to hold the diamond blade in position.
- 2G. NOT USED**
- 2H. BLADE GUARD FRONT:** The front section of the blade guard.
- 2I. BLADE SHAFT:** Supports the blade flanges and blade.

## PRE OPERATION CHECKLIST



Before leaving our factory, every machine is thoroughly tested. Follow our instructions strictly and your machine will give you long service in normal operating conditions.



Before starting up the machine, make sure you read this entire operations manual and are familiar with the operation of the machine.

### WITH MACHINE COLD AND SETTING LEVEL:

1. Check engine oil. Fill to full mark on dip stick with 10W30 oil. DO NOT OVERFILL!!
  - Gas Models: Class MS, SD, SE or better.
2. Electric Models: Verify all electrical connections are intact.

### 1 - 2 HOUR OPERATION CHECK:



**ALWAYS** park machine on a level surface with the engine “OFF” and the engine switch set in the “OFF” position before performing any maintenance. Let the machine cool down!!

1. Tension the blade drive V-belts. DO NOT over tension!!

### SCHEDULED MAINTENANCE QUICK REFERENCE:



Before performing any maintenance, **ALWAYS** park the machine on a level surface with the engine “OFF” and the engine switch set in the “OFF” position.

#### SERVICE DAILY:

1. Check engine oil level.
2. Check blade guard for damage.
3. Check engine air filter, replace if dirty.
4. Lubricate bladeshaft bearings.
5. Lubricate front wheel bearings.
6. Check blade drive V-belt tension. DO NOT over tension!!! Change in sets only!

NOTE: See engine manual for specific engine maintenance for your specific model.

#### SERVICE EVERY 50 HOURS:

1. Replace engine oil and filter.
2. Clean engine/motor air fins.
3. Lubricate depth control adjustment screw. (Screw Feed version only.)
4. Check wheels for wear or damage.



**MANDATORY**



**INDICATION  
INFORMATION  
INSTRUCTION**



**WARNING**



**PROHIBITION**

These signs will give  
advice for your safety



Before leaving our factory every machine is thoroughly tested.

Follow our instructions strictly and your machine will give you long service in normal operating conditions.

## 1 Features

**Use:** Wet sawing of old and new concrete and asphalt.

**Tools:** Diamond blades — water cooled, Ø: 10", 12", 14", 18" and 20" with Arbor Ø - 1"

*(For information, contact your Target supplier)*

CUTTING DEPTHS		
BLADE SIZE	MAXIMUM BLADE DEPTH (To Collar)	MC18 MAXIMUM DEPTH (To Depth Stop)
10" (250mm)	2 3/4" (68mm)	2 1/2" (62mm)
12" (300mm)	3-3/4" (93mm)	3-1/2" (87mm)
14" (350mm)	4-3/4" (118mm)	4-1/2" (112mm)
18" (450mm)	6-3/4" (164mm)	6-1/2" (158mm)



Before starting up the machine, make sure you read this entire manual and are familiar with the operation of this machine.



The working area must be completely clear, well lit and all safety hazards removed.



The operator must wear protective clothing appropriate to the work he is doing.



Any persons not involved in the work, should leave the area.



Use only blades marked with a maximum operating speed greater than the bladeshaft speed.

## 2 Assembly

- The Handle must be attached. Place Handle in position and securely tighten Knobs.
- Check the engine oil level. Service before using. Refer to the engine operation manual for detailed information.

## 3 General Instructions



Remove the Blade (2E) before transport.



**WARNING: DO NOT** operate without the proper blade guard over the Blade! (2E)



**WARNING: DO NOT** operate the saw with the front of the Blade Guard (2H) raised!



**WARNING: Blade exposure CANNOT** exceed 180 degrees when operating!

- The Front Pointer must be checked for alignment with the Blade (2E). It must be in line with the Blade (2E) mounted on the Blade Shaft (2I).
- For WET SAWING, be sure the water jets in the blade guard water tubes are open and that each side of the Blade (2E) has an adequate supply of water. Test the water supply for pressure and quantity (flow) before starting to saw.



**WATER FLOW** from 2-1/2 to 5 gallons of water per minute **MUST** flow over the blade to properly cool it and to get maximum blade life. **DO NOT** use conventional (wet) diamond blades without water!

- Saw only as deep as the specifications and job conditions require. Sawing excessively deep is wasteful—avoid it! Step cut in increments of 2 inches (50 mm) for best results.
- Saw in a straight line. Mark the cutting line clearly so the saw operator can follow the line without difficulty. The saw should NOT be twisted from side to side trying to force the blade back on the line.

## 4 Check Before Starting



Take into account the working conditions from the health and safety point of view.

**FUEL:** Check the engine maintenance manual.

\* Gas Models: Unleaded gasoline is recommended.

- Check that the engine oil level is correct. Because the engine often operates at an angle, check the oil level (with engine horizontal) frequently to ensure that the oil level never falls below the lower mark on the dipstick. 10W30 oil is recommended.

## 5 Fitting The Blade

(See Fig. 1 and 2)



Always set the Engine Switch (1D) to the "OFF" position before mounting the Blade (2E).

- Set the Engine Switch (1D) to the "OFF" position.
- Raise the machine to a high position [by cranking the Raise/Lower Hand Wheel] or [by loosening and tightening the E-Z Tilt Handle].
- Raise the front half of the Blade Guard (2H).
- Unscrew the Blade Shaft Nut (2A). Remove Outer Flange (2B).
- Fit Diamond Blade (2E) on the Blade Shaft Arbor.
- Install Outer Flange (2B) into the Blade Shaft (2I) making sure that the Locking Pin (2D) passes through the Diamond Blade (2E) and into the Inner Flange (2F).



Note the direction of rotation of the blade. The direction of rotation is shown by an arrow on the Diamond Blade (2E). Make sure that the contact surfaces on the Diamond Blade (2E), Inner & Outer Flanges (2B & 2F) and Blade Arbor are clean.

- Rotate Outer Flange (2B) and the Blade (2E) in the opposite direction of blade rotation to remove backlash.
- Install and tighten Blade Flange Nut using the Blade Shaft Wrench [50 lb.-ft. (68 N-m)] while firmly holding the Diamond Blade (2E).
- Lower front half of Blade Guard (2H).



The Blade Shaft Nut (2A) on the Right Hand side has Left Hand threads.

## 6 Starting The Power Source



Always pay extreme care and attention to the preparation of the machine before starting.



Remove all wrenches and tools from the floor and the machine.



Always keep blade guard and transmission guard in place.

### On Gasoline Engine Models:

1. Refer to the engine operating manual for proper engine operation.
2. Fill the engine fuel tank and check the engine oil level. Refer to the engine manual for detailed information.
3. Start the engine. Refer to the engine manual for detailed information.
4. Let the engine warm up at half throttle. All sawing is done at full throttle. The governor is factory set for the correct engine speed. **Do not change the Governor setting** – it is factory set for the correct speed.



**WARNING: To STOP ENGINE, PUSH the Engine Stop Switch DOWN, located on the handle support of the saw. [Wait for all engine movement to stop.]**

### On Air Models:

1. Connect the saw to an adequate air supply of 175 CFM @ 100 PSI (120 CFM @ 90 PSI per minute).
2. Check the lubricator (located in the air manifold unit) for the proper oil level. If you need oil, unscrew the plug and fill with an SAE #10 Wt. detergent automotive engine oil. The oil should always be visible in the sight glass. Do not overfill.
3. Open the air valve located in the air manifold unit. The air motor should be free wheeling. The lubricator should be adjusted to feed 4 drops per minute. Monitor the drip rate through the sight-feed dome. Turn the adjustment screw counterclockwise to increase the drip rate and clockwise to decrease it.

### On Electric Models:

1. Single phase concrete saws are furnished with the correct approved NEMA configuration plug on the motor pigtail. It will be necessary to provide a matching NEMA configuration receptacle on the extension cord into which the motor is connected. For example: a 5 HP saw set for 230 volts operation is supplied with a NEMA #L6-30P plug on the pigtail. The extension cord will require an L6-30R to make the proper connection.



## WARNINGS!!!

- DO** turn the "ON/OFF" switch to the "OFF" position prior to connecting the machine to the power source.
- DO** make sure electric powered machines are plugged into a properly grounded circuit.
- DO** make sure power cords are the proper size and in good condition.
- DO** follow all electrical codes in your area.
- DO** use correct voltage and proper extension cords. Never carry tool by cord or yank it to disconnect it from receptacle. Keep cord away from heat, oil and sharp edges.
- DO** disconnect tools from power source when not in use, before servicing and when changing accessories.
- DO** carefully maintain and clean for better and safer performance. Follow instructions for changing accessories. Inspect tool cords periodically and, if damaged, have repaired by authorized service facility.
- DO NOT** lay power cords in or near the water.
- DO NOT** leave this machine unattended with the motor running.
- DO NOT** replace the motor with any motor that does not have a special grounding connection.

2. Electric motors of any make can burn out when the voltage supply falls 10% below the voltage rating of the motor. Use proper heavy duty fuses in the circuit. Use No. 8 wire for extension cord lengths up to 100 ft. long. Under-sized wires can cause motor burnout. Check the voltage at the motor when the saw is cutting.
3. Single phase concrete saw motors are equipped with manual reset overloads. When the overload trips, turn the switch to the **OFF** position. Allow the motor to cool 5 to 10 minutes, then push the reset button. A click indicates reset.

### 7 To Maneuver the Saw

- Set the handle bar height to a comfortable position.
- Raise the Blade (2E) as high as possible so that the Blade (2E) will not strike pavement when maneuvering.

### 8 To Start Sawing

- Follow all of the instructions outlined above.
- Open the Water Valve (1A) FULL open. Check the water to verify full flow, then adjust for proper amount of water on the blade BEFORE you lower the Blade.



**Test for adequate water supply [2-1/2 to 5 gal/min (10 to 20 lit./min)]. Low water flow will cause damage to diamond blades.**



**If water supply is interrupted, stop cutting immediately.**

#### Screw Feed Version:

- Lower the blade into the cut by pulling up on the Depth Control Lock (1E) and slowly turning the Hand Wheel COUNTER-CLOCKWISE. When the desired depth of cut is reached, push Depth Control Lock down to lock it in the hand wheel.

#### E-Z Tilt Version:

- The blade on this saw may be lowered into the concrete by loosening the lock handle and pushing forward on the handle bar. The weight of the saw will assist when lowering the blade. The blade is held at the desired depth by tightening the lock handle on the lock bar.
- During cutting, DO NOT exert excessive side pressure on the Handle Bars to attempt to "STEER" the saw. Use only enough pressure to follow the previously marked line.
- If the saw should stall for any reason, (close the air valve on the air models and turn the power switch off on the electric models) raise the blade completely out of the cut before starting your power source again!
- When lowering the Blade (2E) into a partially made cut, the blade must be perfectly aligned within the cut before starting to saw again. DO NOT FORCE the Blade (2E) into the material by lowering the Blade too fast, or by propelling the saw too fast.

### 9 Stopping the Saw

- Screw Feed Version:  
Raise the blade out of the cut by pulling up on the depth control lock and slowly turning the hand wheel clockwise. Raise the blade (2E) high enough out of the cut to clear the pavement when maneuvering the saw.
- E-Z Tilt Version:  
Raise the blade out of the cut by loosening the lock handle and pulling back on the handle bar. Raise the blade (2E) high enough out of the cut to clear the pavement when maneuvering the saw when tightening the lock handle.
- Turn off the Water Valve (1A).
- Turn the Engine Throttle to the IDLE position.
- STOP the engine by turning the Engine Switch (1D) to the OFF position.



**Before performing any maintenance, ALWAYS park the machine on a level surface with the Engine OFF and the Engine Switch in the "OFF" position.**

After each use: **CLEAN** the machine.

#### LUBRICATION:



#### LUBRICATE DAILY

Front Wheels and Blade Shaft Bearings

#### LUBRICATE EVERY 50 HOURS

Depth Control Adjustment Screw (Screw Feed Version Only)

NOTE: When cutting dry, lubricate blade shaft bearings 2 or 3 times daily, the grease provides an added protective seal for the bearings. Use only a Premium Lithium 12 based Grease, conforming to NLG1 Grade #2 Consistency, without Molybdenum Disulfide.

#### ENGINE OIL:

Check daily. Keep the oil clean and at the proper level. 10W30 MS, SD, SE or better is generally recommended. Capacity levels indicated on page 10. **DO NOT OVER-FILL!!** Change engine oil and oil filter every 50 HOURS of operation. Refer to the engine manual for detailed information.

#### CLEAN ENGINE AIR FILTER:

Clean the air filter 2 or 3 times daily when dry cutting. Refer to the engine manual for detailed information.

#### ENGINE CARE:

Refer to the engine manual for detailed information.

##### A. On Air Models:

A filter with a lubricator and a shut-off valve has been provided on the saw. Lubrication of the air motor is required. Lubrication is necessary for all internal moving parts and rust prevention. The filter removes excessive moisture in the air line that can cause rust formation in the motor and might also cause ice to form in the muffler due to expansion of air thru the motor.

The filter has a manual drain and must be drained as frequently as necessary to keep the liquid level in the bowl below the baffle. If the liquid level rises above the baffle, liquid will be carried into the air motor.

##### B. On Electric Models:

Check the extension wire size. Under-sized wires can cause motor burn out. Use No. 8 wire for extension cord lengths up to 100 ft. long

#### BLADE SHAFT V-BELTS:

This concrete saw is equipped with "3VX" premium V-belts. These belts are properly tensioned at the factory. Severe damage or breakage of the crankshaft can occur if the belts are tensioned too tightly. Check the belt tension as set on the new saw and NEVER set belts beyond the original tension. Not enough tension will destroy the belts quickly, and the belts should NEVER be allowed to slip. After one (1) hour of use, retension the belts to make up for initial stretch. A V-belt tension tester should be used to obtain accurate V-belt tension settings. Check the setting in a SINGLE belt of a set of V-belts. Apply the load at the center of the belt span. Deflection should be 3/16" (5mm) with a 5 to 6 lb. (2.3 to 2.7 kg.) load. **Replace the belts in sets only.**

#### SPECIAL OUTER FLANGE ASSY 1/2" (12.7mm)

##### WIDE CUT (P/N 167963)

- A Special Outer Flange Assembly is available as a field installed accessory. It enables the MC 18 to cut 7/16" - 1/2" (11-12.7mm) wide.



**WARNING: This special outer flange assembly is for use with blade width stacks of 7/16" - 1/2" (11mm-12.7mm) only! If blade width stacks of less than 7/16" (11mm) are required, use the standard outer flange assembly supplied with the MC 18. The Special Outer Flange Assembly can be identified by the COUNTERBORE on the "Nut Side" of the flange. The Standard Outer Flange Assembly has NO COUNTERBORE.**

#### WATER TANK KIT

- A 6 gallon (23 liter) Water Tank Kit is available as a Field installed accessory. Use only for dry cutting! The water tank is designed only to suppress airborne concrete dust.



**WARNING: DO NOT use conventional (wet) diamond blades with the water tank as the water source, because there is not sufficient water flow available to properly cool the blades!**

#### TIE DOWN BRACKET KIT (P/N 167189)

- A Tie Down Bracket Kit is available as a field installed accessory. The kit consists of two (2) tie down loops that are installed at the front of the frame. They are to be used only to SECURE the saw to a truck or trailer during transport.



**WARNING: DO NOT use the tie down brackets as a device for lifting the saw!**

## 12 Governor Speed

It is critical that the Governor and throttle on all internal combustion engines be adjusted properly. The engine speed is preset at the factory for the proper sawing speed. It is NOT normally necessary to change this setting. It should be periodically verified after the saw is placed into service. To change the Governor setting, refer to the engine manual.



**WARNING: Overspeeding the blade can result in blade breakage and/or personal injury to the operator and bystanders!! To assure the proper Governor adjustment, determine the correct blade shaft speed from the following chart. Follow the engine manufacturer's instruction procedure for Governor and throttle setting.**

NO LOAD BLADE SHAFT AND ENGINE R.P.M.s		
MODEL	BLADE SHAFT R.P.M.	ENGINE R.P.M.
5 AIR MOTOR 14"/18"	1800	2500
5E, 1PH-14"/18"	2505	3450
9R 14"/18"	2570	4000
9H 14"/18"	2610	3600
13.5R-14"/18"	2610	3600
13H-14"/18"	2610	3600

## 13 Repairs

We carry out all repairs in the shortest possible time and at the most economical prices. (See front page for our address and phone numbers.)

## 14 Service Parts

For quick supply of spare parts and to avoid any lost time, it is essential to quote the data on the manufacturer's plate fixed to the machine and the part number (s) to be replaced with every order.

Write the Model Number & Serial Number here for future reference:

Model Number: \_\_\_\_\_

Serial Number: \_\_\_\_\_

*The instructions for use and spare parts found in this document are for information only and are not binding. As part of our product quality improvement policy, we reserve the right to make any and all technical modifications without prior notice.*



**The manufacturer accepts no responsibility caused by unsuitable use or modifications**

**NOTE:**  
**NOTA:**

# Diagram 1 – Frame & Axle

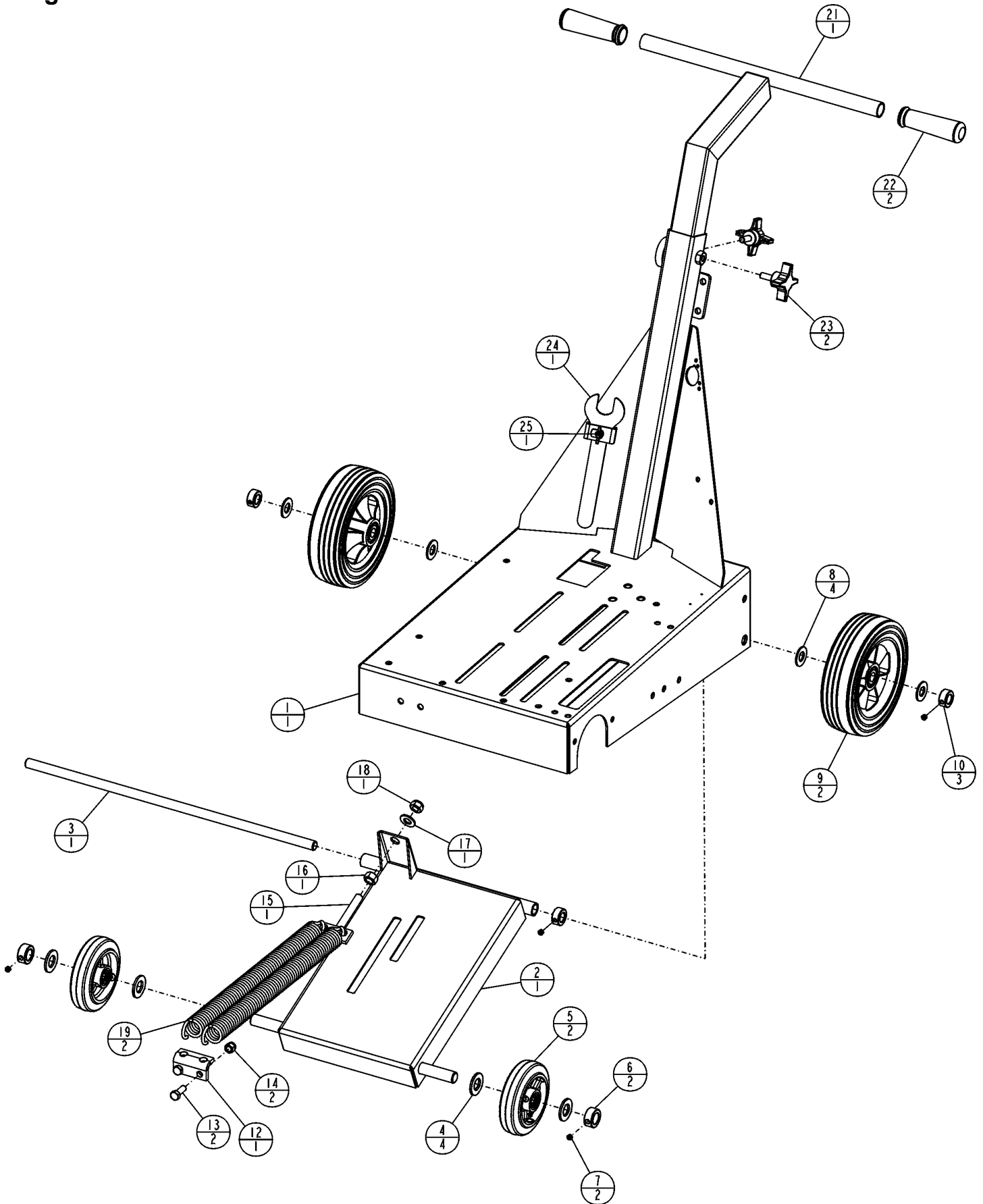

# Diagram 1 – Frame & Axle

(Rev July 11, 2002)

BILL OF MATERIAL			
INDEX	P/N	DESCRIPTION	QTY
1	174939	Frame Weldment, MC18	1
2	174942	Axle, Front	1
3	174975	Axle, Pivot	1
4	020768	Washer, Flat .75 SAE	4
5	040091	Wheel Assy, 5 Inch Dia	2
6	041160	Lock Collar, .750 ID (w/ss)	2
7	020551	Screw, Set Soc Cup Pt .312-18UNC x .25	1
8	020767	Washer, Flat .625 SAE	4
9	139569	Wheel, 8 Inch Dia	2
10	049923	Lock Collar, .625 w/SS	3
11	020551	Screw, Set Soc Cup Pt .312-18UNC x .25	1
12	139638	Anchor, Spring	1
13	020323	Capscrew, Hex Hd .375-16UNC x 1.00	2
14	020199	Locknut, Fiber .375-16UNC	2
15	139582	Bolt, Tension	1
16	020140	Nut, Std Hex .500-13UNC	1
17	020766	Washer, Flat .500 SAE	1
18	020201	Locknut, Fiber .500-13UNC	1
19	139581	Spring	2
21	174946	Handle, Bent	1
22	139568	Grip, Handle	2
23	177557	Knob, 3/8-16UNC-2A x 1.00	2
24	163988	Wrench, 1-1/16" Open End	1
25	197170	Wing Bolt, M6 x 1.0 x 16 mm	1

## Diagram 2 – Depth Control (Screw Feed)

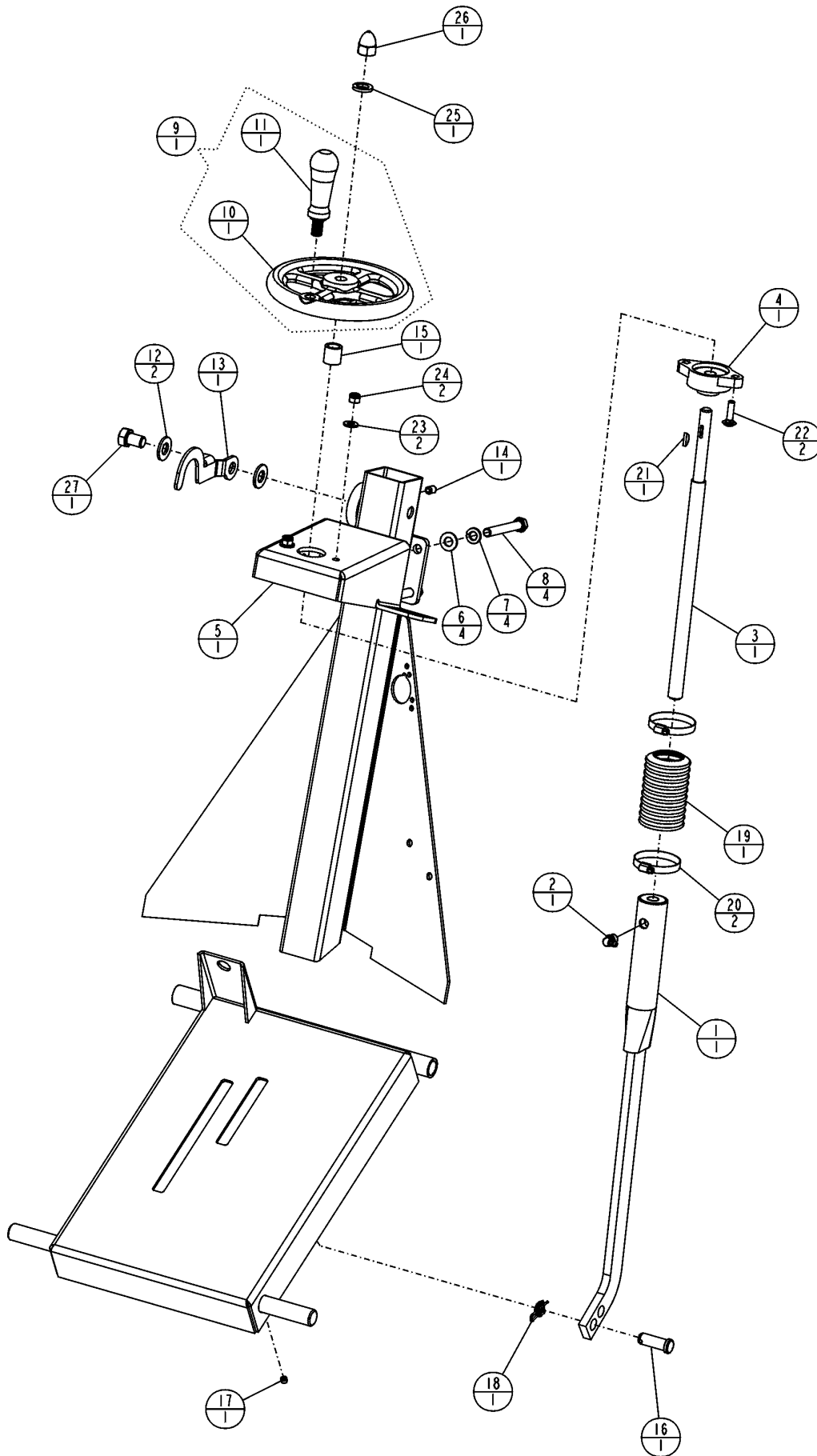

## Diagram 2 – Depth Control (Screw Feed)

BILL OF MATERIAL			
INDEX	P/N	DESCRIPTION	QTY
1	174997	Adj Nut Wldmnt w/ Grease Fit	1
2	049924	Fitting, Grease 1/8 NPT x 90°	1
3	177915	Screw, Adj., .625-8 ACME	1
4	040141	Bearing, Flange, .50 Inch ID	1
5	174944	Bracket, Screw Feed	1
6	020764	Washer, Flat .375 SAE	4
7	020786	Lockwasher, Split .375	4
8	020330	Capscrew, Hex Hd .375-16UNC x 3.00	4
9	040153	Assy, Hand Wheel	1
10	040151	Wheel, Hand - Machined	1
11	032250	Handle Assy, Revolving	1
12	020766	Washer, Flat .500 SAE	2
13	174956	Bracket, Stop	1
14	020552	Screw, Set Soc Cup Pt .312-18UNC x .50	1
15	174994	Spacer, Adjustment Screw	1
16	160164	Pin, Clevis .50 Dia x 1.13 Lg	1
17	020540	Screw, Set Soc Cup Pt .250-20UNC x .25	1
18	177239	Pin, Rue Ring - .50 DIA	1
19	040183	Rubber Boot, 3 Inch (20 ribs)	1
20	174961	Hose Clamp, Worm Drive SAE 24 Narrow	2
21	020010	Key, Woodruff #405	1
22	020012	Bolt, Carriage .250-20UNC x 1.00	2
23	020762	Washer, Flat .250 SAE	2
24	020195	Locknut, Fiber .250-20UNC	2
25	020788	Lockwasher, Split .500	1
26	030210	Nut, Acorn LT .500-13UNC	1
27	020668	Capscrew, Hex Hd .500-13UNC x .75	1
28	174998	Decal, Screw Feed	1

# Diagram 3 – Depth Control (Lock Bar)

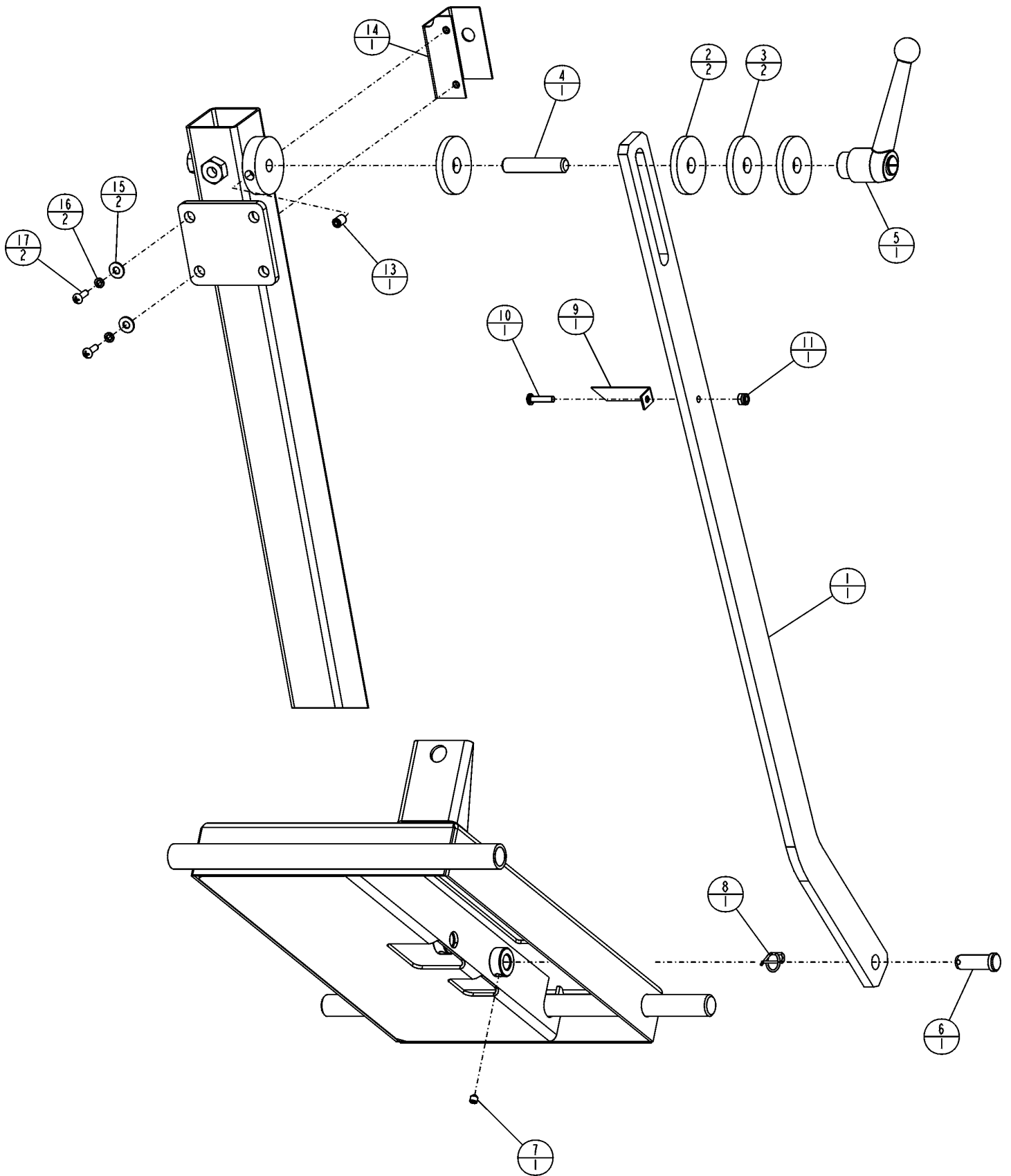

### Diagram 3 – Depth Control (Lock Bar)

BILL OF MATERIAL			
INDEX	P/N	DESCRIPTION	QTY
1	139560	Bar, Lock	1
2	049513	Washer, Friction .531 ID	2
3	139562	Washer	2
4	139556	Stud, Depth Control	1
5	174679	Lever, Adjustment	1
6	160164	Pin, Clevis .50 Dia x 1.13 Lg	1
7	020540	Screw, Set Soc Cup Pt .250-20UNC x .25	1
8	177239	Pin, Rue Ring - .50 DIA	1
9	139626	Pointer, Depth	1
10	020461	Screw, Mach Ph Hd #10-24UNC x .875	1
11	020194	Locknut, Fiber #10-24UNC	1
12	139633	Decal, Depth of Cut	1
13	020552	Screw, Set Soc Cup Pt .312-18UNC x .50	1
14	196000	Bracket, Switch	1
15	020740	Washer, Flat .188 Dia	2
16	020782	Lockwasher, Split #10	2
17	196034	Screw, Rd Hd Mach 10-24 x .625 Cross Z/P	2

# Diagram 4 – Pointer & Belt Guard

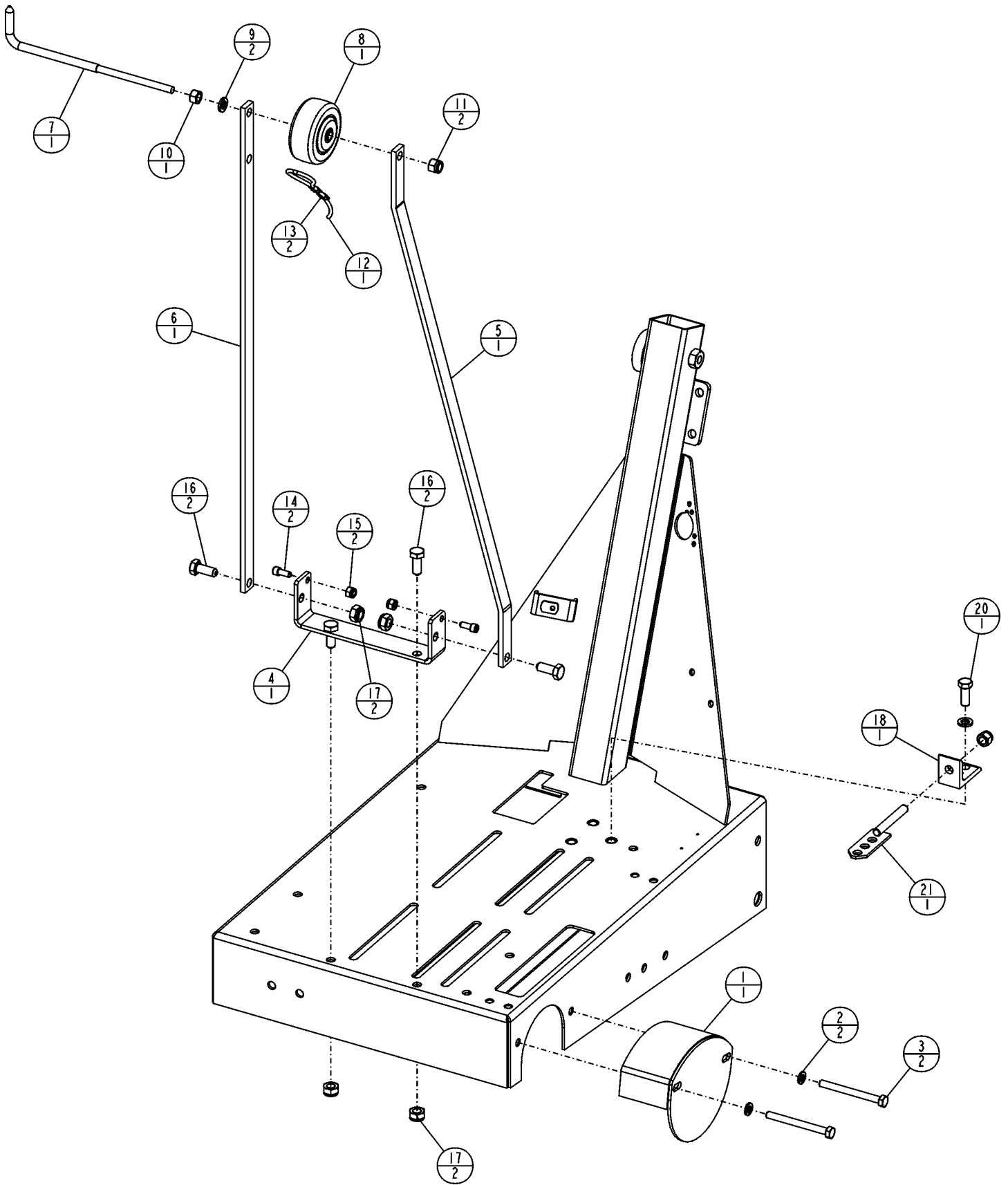

## Diagram 4 – Pointer & Belt Guard

BILL OF MATERIAL			
INDEX	P/N	DESCRIPTION	QTY
1	174328	Guard, Shaft - Weldment	1
2	020785	Lockwasher, Split .313	2
3	020399	Capscrew, Hex Hd .312-18UNC x 3.25	2
4	174977	Bracket, Pointer Mount	1
5	167908	Bar, Pointer - Offset	1
6	167906	Bar, Pointer - Straight	1
7	041231	Rod, Pointer	1
8	041220	Wheel, 3in Dia	1
9	020786	Lockwasher, Split .375	1
10	020136	Nut, Std Hex .375-16UNC	1
11	020199	Locknut, Fiber .375-16UNC	1
12	172137	Rope, Pointer	1
13	162761	Clamp	2
14	020395	Capscrew, Soc Hd .250-20UNC x .625	2
15	020195	Locknut, Fiber .250-20UNC	2
16	139749	Capscrew, Hex Hd M10 x 1.50 x 25mm	4
17	139748	Locknut, Fiber M10 x 1.50	4
18	040550	Hinge Block, Pointer	1
19	020786	Lockwasher, Split .375	1
20	020323	Capscrew, Hex Hd .375-16UNC x 1.00	1
21	177696	Draw Bolt, 3/8-16UNC	1
22	020199	Locknut, Fiber .375-16UNC	1

# Diagram 5 – Guards & Water Distribution

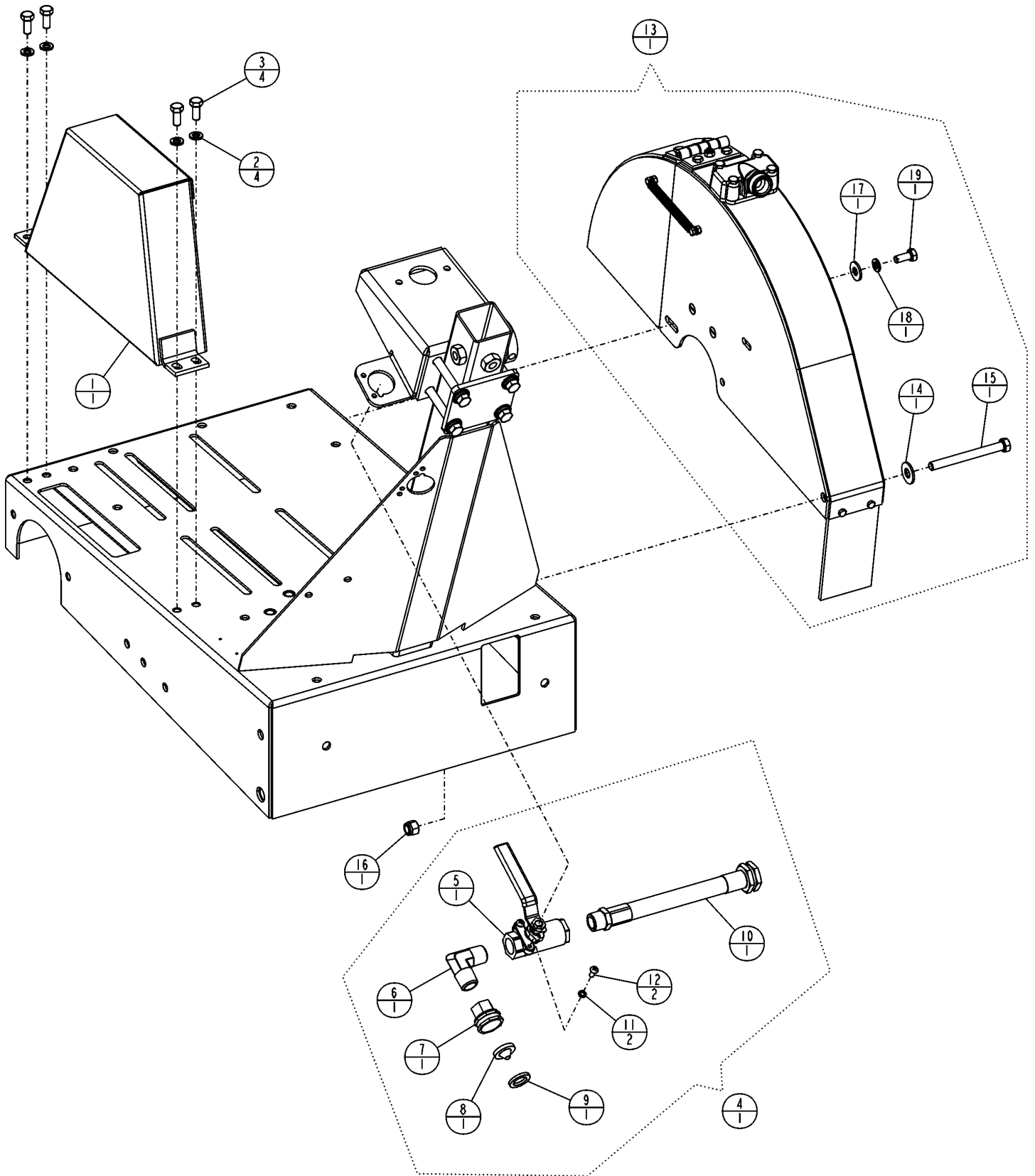

## Diagram 5 – Guards & Water Distribution

BILL OF MATERIAL			
INDEX	P/N	DESCRIPTION	QTY
1	174953	Guard, Belt	1
2	020785	Lockwasher, Split .313	4
3	020313	Capscrew, Hex Hd .312-18UNC x .75	4
4	174992	Water Valve Assy, MC18	1
5	139021	Water Valve	1
6	169196	Elbow, 1/2NPT Male x 90° Brass	1
7	040270	Hose Adapter	1
8	045640	Filter Washer	1
9	040254	Washer, Hose	1
10	139616	Hose Assy, Water - MC18	1
11	020782	Lockwasher, Split #10	2
12	196039	Screw, Rd Hd Mach 10-24 x .500 Cross Z/P	2
13	196042	Assy, Blade Guard - 18in Tgt Blue	1
14	020743	Washer, Flat .375 Dia	1
15	020233	Capscrew, Hex Hd .375-16UNC x 3.75	1
16	020199	Locknut, Fiber .375-16UNC	1
17	020742	Washer, Flat .313 Dia	1
18	020785	Lockwasher, Split .313	1
19	020313	Capscrew, Hex Hd .312-18UNC x .75	1

# Diagram 6 – Blade Guard

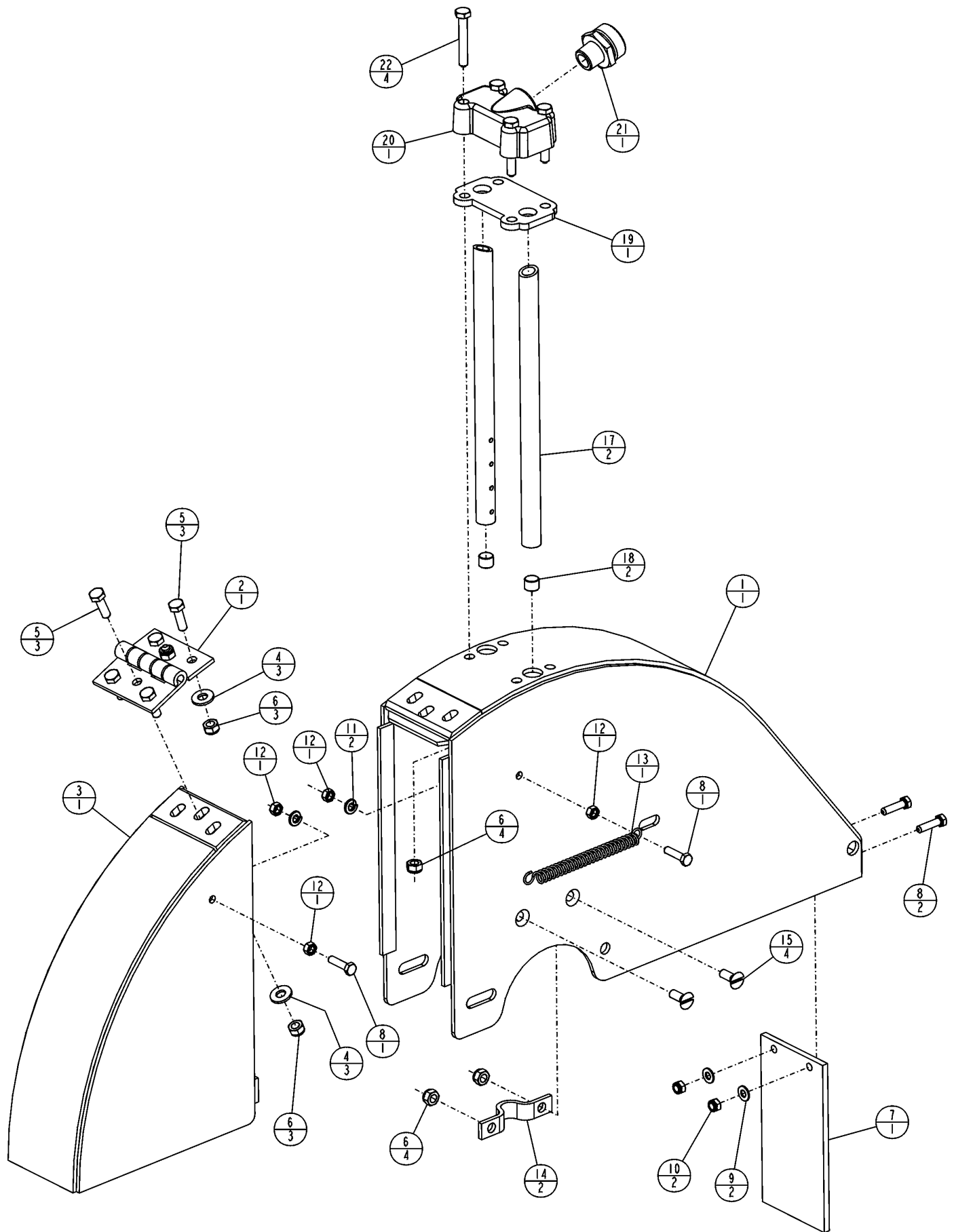

# Diagram 6 – Blade Guard

(Rev July 11, 2002)

BILL OF MATERIAL			
INDEX	P/N	DESCRIPTION	QTY
1	-----	Rear Guard Weldment - 18 Inch	1
2	139075	Hinge (Note A)	1
2A	195127	Hinge (Note A)	1
3	139596	Front Guard Weldment, 18 Inch (Note A)	1
3A	195120	Front Guard Weldment, 18 Inch (Note A)	1
4	020762	Washer, Flat .250 SAE (Note A)	6
4A	173059	Washer, Flat M8 (Note A)	6
5	139761	Capscrew, Hex Hd M6 x 1.0 x 20mm (Note A)	6
5A	167478	Capscrew, Hex Hd M8 x 1.25 x 25mm (Note A)	6
6	139745	Locknut, Fiber M6 x 1.0 (Note A)	6
6A	139738	Locknut, Fiber M8 x 1.25 (Note A)	6
7	139098	Splash Flap	1
8	167761	Capscrew, Hex Hd M5 x 0.8 x 20mm	4
9	173047	Washer, Flat M5	2
10	172316	Locknut, Fiber M5 x 0.8	2
11	020782	Lockwasher, Split #10	2
12	172011	Nut, Hex Hd M5 x 0.80	4
13	040330	Spring, .375 OD x .054 Dia	1
14	049212	Clamp, Water Tube	2
15	167818	Capscrew, Slot Flat Hd M6 x 1.0 x 16mm	4
16	139745	Locknut, Fiber M6 x 1.0	8
17	167046	Water Tube, 18 Inch	2
18	020864	Plug, Soc Hd 1/8 NPT Brass	2
19	139051	Gasket, Water Manifold	1
20	139045	Water Manifold, Machined	1
21	040275	Adapter, 3/8 NPT x Male Garden Hose	1
22	167551	Capscrew, Hex Hd M6 x 1.0 x 40mm	4

## NOTE A:

For P/N 195127 Hinge (1/4" Thick) use P/N 195120 Front Guard Weldment - 18" and use hardware (Item 4A, 5A & 6A).

For P/N 139075 Hinge (1/8" Thick) use P/N 139596 Front Guard Weldment - 18" and use hardware (Item 4, 5 & 6).

# Diagram 7 – Engine & Bladeshaft

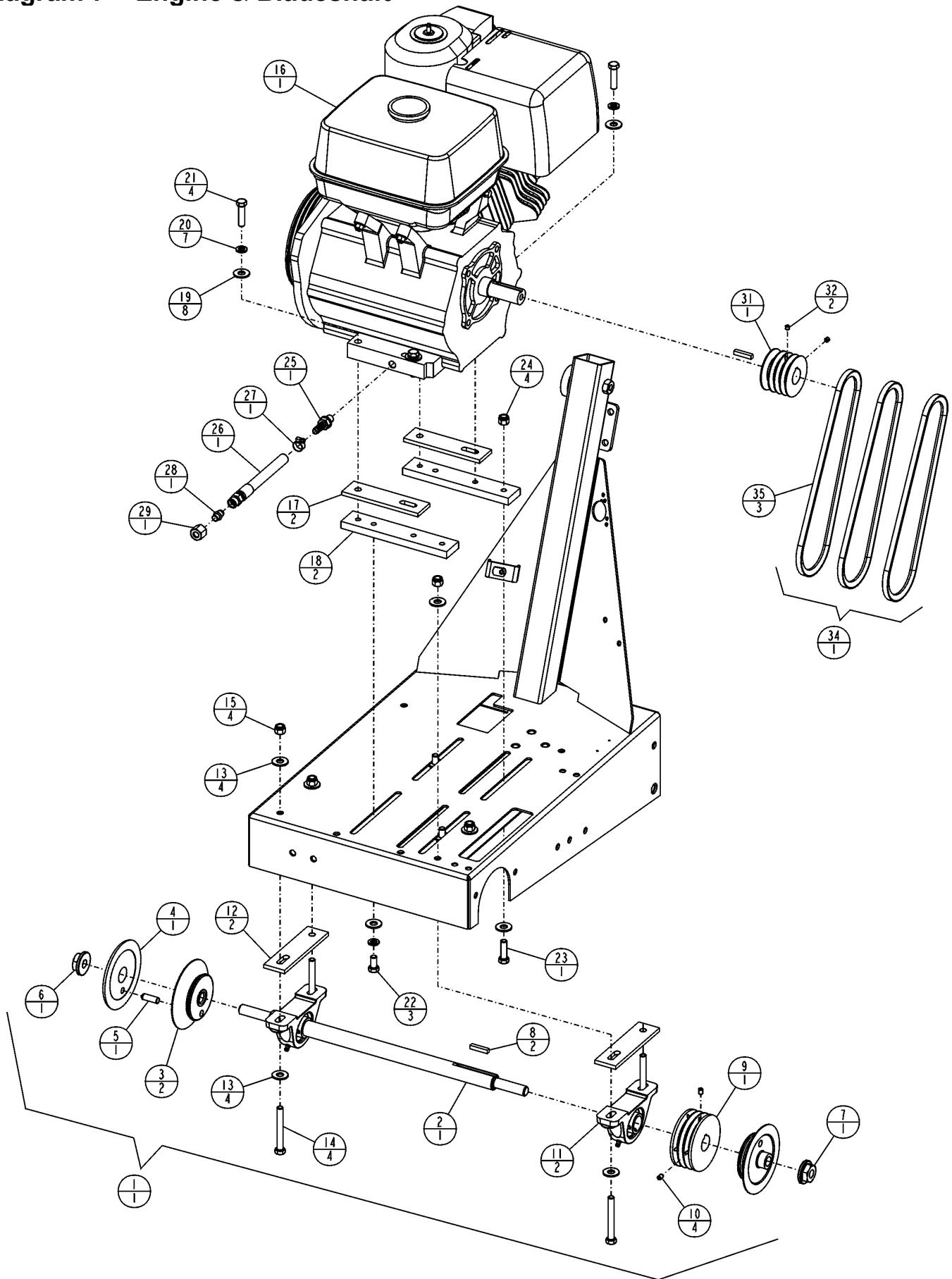

## Diagram 7 – Engine & Bladeshft

BILL OF MATERIAL			
INDEX	P/N	DESCRIPTION	QTY
1	174973	Group, Bladeshft R&L 4.5 (9H,13H,13R)	1
-	196003	Group, Bladeshft R&L 4.5 (9R Only)	1
2	177569	Bladeshft Assy, Complete (9H,13H,13R)	1
-	196004	Bladeshft Assy, Complete (9R Only)	1
3	167185	Collar, Inner 4.50 OD	2
4	167962	Collar, Outer 4.50 OD Assy	1
5	167964	Pin, Drive	1
6	167846	Nut, LH Thread, Bladeshft	1
7	167847	Nut, RH Thread, Bladeshft	1
8	020067	Key, Square .250 x 1.25 Lg	1
9	139300	Pulley Assy, 3GR 3V 3.65 (9H,13H,13R)	1
-	196005	Pulley Assy, 3GR 3V 4.12 (9R Only)	1
10	020541	Screw, Set Soc Cup Pt .250-20UNC x .375	4
11	162633	Bearing, lin Pillowblock BB	2
12	174962	Spacer, Bearing	2
13	020743	Washer, Flat .375 Dia	8
14	020330	Capscrew, Hex Hd .375-16UNC x 3.00	4
15	020199	Locknut, Fiber .375-16UNC	4
16	177958	Engine, 13HP Honda - Modified	1
--	196010	Engine, 13HP Robin - Modified	1
--	167751	Engine, 9HP Honda - Modified	1
--	196008	Engine, 9HP Robin - Modified	1
17	174962	Spacer, Bearing (9R,13R,13H)	2
18	174736	Plate, Adapter (13H Only)	2
19	020743	Washer, Flat .375 Dia	8
20	020786	Lockwasher, Split .375 (13H Only)	7
21	020377	Capscrew, Hex Hd .375-16UNC x 1.50 (13H)	4
--	020380	Capscrew, Hex Hd .375-16UNC x 1.75 (9H)	4
--	020509	Capscrew, Hex Hd .375-16UNC x 2.00 (9R,13R)	4
22	020322	Capscrew, Hex Hd .375-16UNC x .75 (13H)	3
23	048740	Capscrew, Hex Hd .375-16UNC x 1.25 (13H)	1
24	020199	Locknut, Fiber .375-16UNC	4
25	167133	Adapter, M12 x 10mm Hose Barb (9H,13H)	1
--	167138	Adapter, M14 x 1.5M x .25NPTF (9R,13R)	1
--	15700887	Fitting, .25NPT x .375HB (9R,13R-Not Shown)	1
26	167305	Hose Assembly, Oil Drain	1
27	020049	Hose Clamp, Worm Drive	1
28	167306	Cap, Blanking	1
29	167622	Tube Nut, M16	1
30	174999	Assy, Cord	1
31	167746	Pulley Assy, 3G3V 2.65 Dia (w/ss)	1
32	020540	Screw, Set Soc Cup Pt .250-20UNC x .25	2
33	020067	Key, Square .250 x 1.25 Lg	1
34	139613	V-Belt, 3VX300 [set of 3](9R,13H,13R)	1
--	139614	V-Belt, 3VX280 [set of 3](9H Only)	1
35	047455	V-Belt, 3VX300 (9R,13H,13R)	3
--	058020	V-Belt, 3VX280 (9H Only)	1

# Diagram 8 – Electric Motor

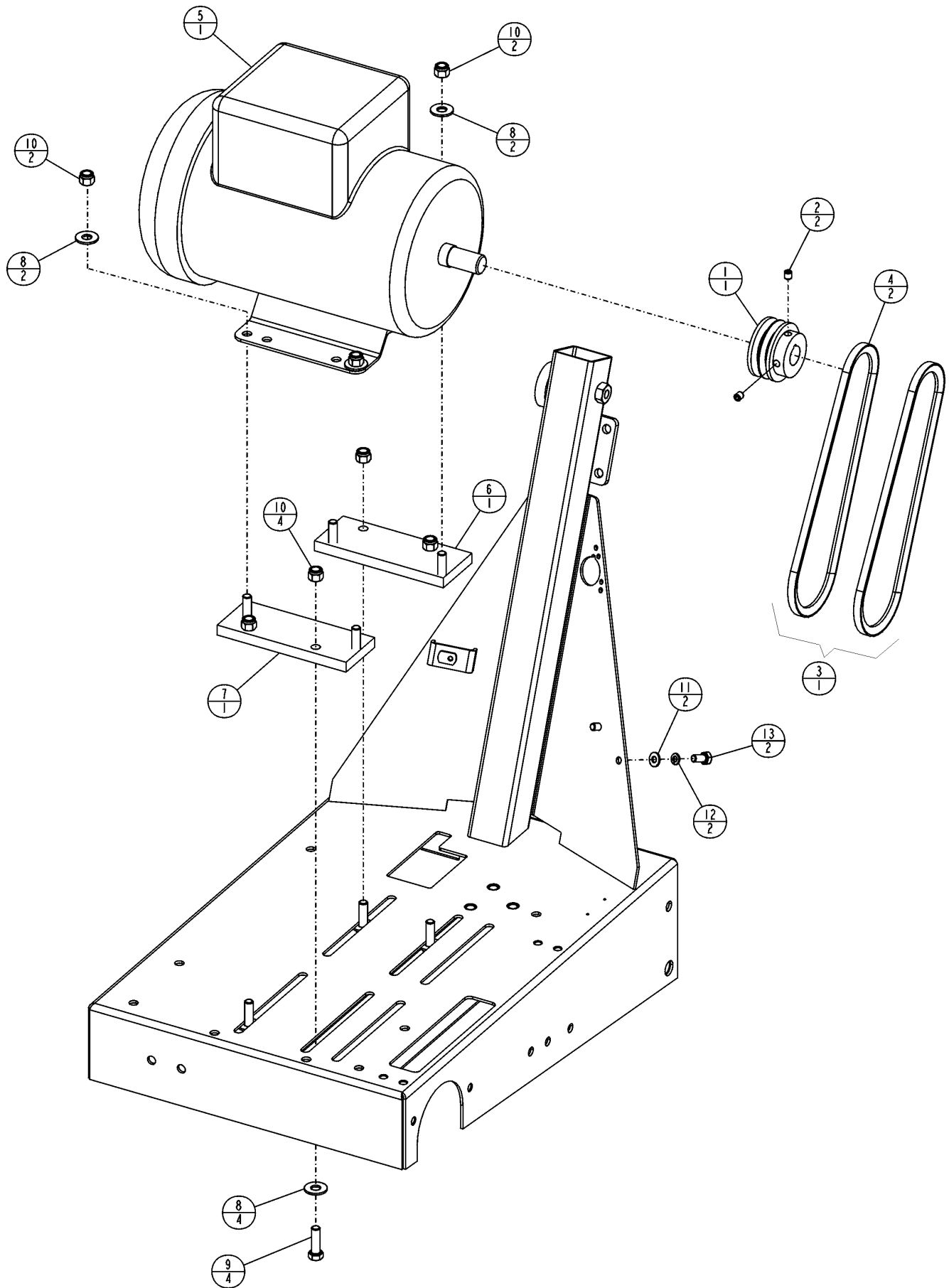

## Diagram 8 – Electric Motor

BILL OF MATERIAL			
INDEX	P/N	DESCRIPTION	QTY
1	060143	Pulley, 2G3V 2.65 x .875 Bore	1
2	020550	Screw, Set Soc Cup Pt .312-18UNC x .375	2
3	139612	V-Belt, 3VX280 (Set of 2)	1
4	058020	V-Belt, 3VX280	2
5	139306	Motor, 5HP 230/60 Alt Wiring	1
-	000923	Motor, 5HP 3450 208-230/460/60	1
6	139540	Adapter, L.H.	1
7	139538	Adapter, R.H.	1
8	020743	Washer, Flat .375 Dia	8
9	048740	Capscrew, Hex Hd .375-16UNC x 1.25	4
10	020199	Locknut, Fiber .375-16UNC	8
11	020762	Washer, Flat .250 SAE	2
12	020784	Lockwasher, Split .250	2
13	020301	Capscrew, Hex Hd .250-20UNC x .625	2

# Diagram 9 – Air Motor

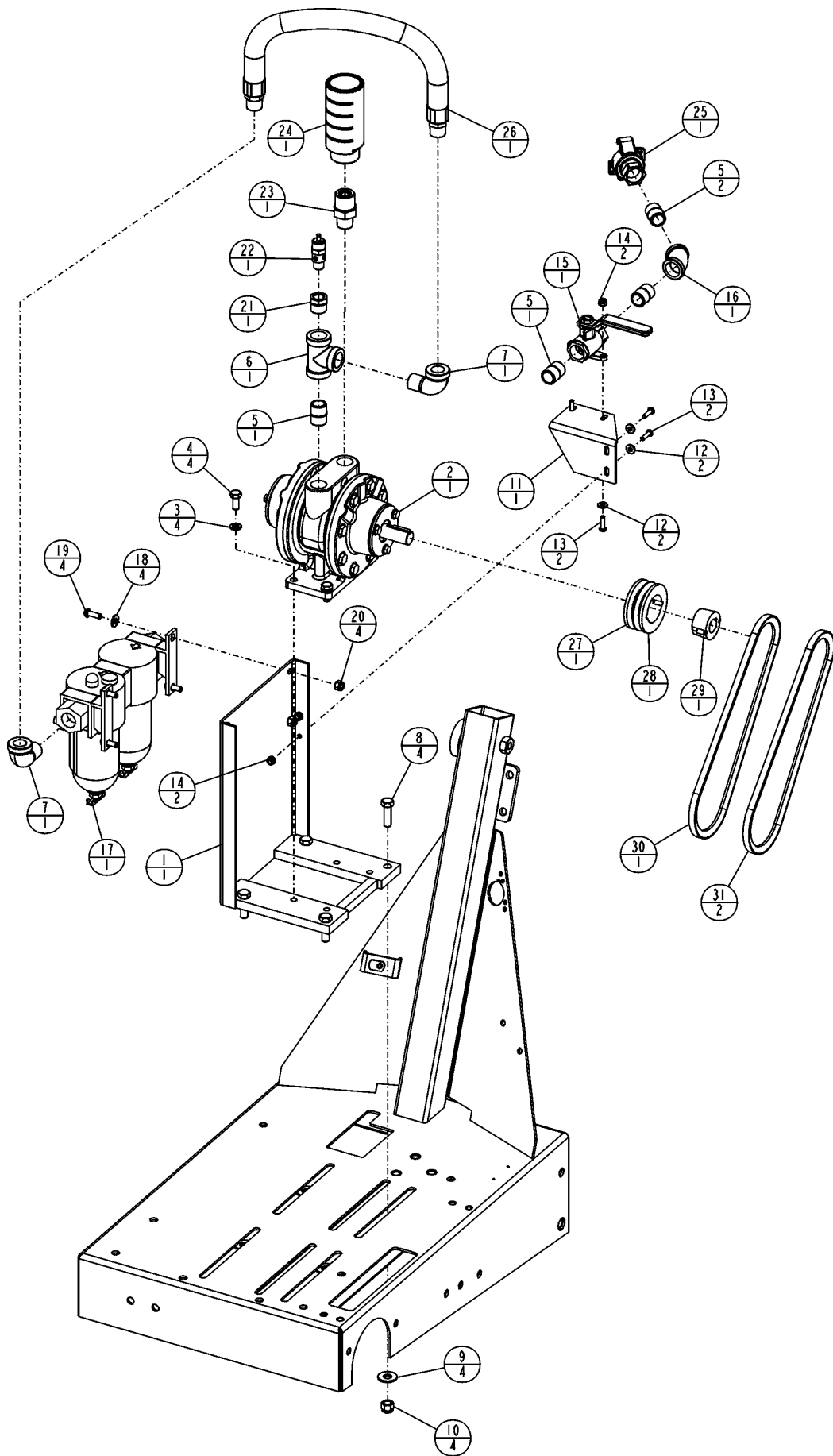

## Diagram 9 – Air Motor

BILL OF MATERIAL			
INDEX	P/N	DESCRIPTION	QTY
1	139644	Air Motor Mount	1
2	139624	Air Motor	1
3	020785	Lockwasher, Split .313	4
4	020313	Capscrew, Hex Hd .312-18UNC x .75	4
5	020293	Nipple, Close 1/2 NPT	4
6	020730	Tee, Female, 1/2 NPT, Galvanized	1
7	020810	Elbow, Street, 90° x 1/2 NPT	2
8	048740	Capscrew, Hex Hd .375-16UNC x 1.25	4
9	020743	Washer, Flat .375 Dia	4
10	020199	Locknut, Fiber .375-16UNC	4
11	139646	Air Valve Mount	1
12	020739	Washer, Flat #10 SAE	4
13	020408	Screw, Mach Rd Hd #10-24UNC x 0.75	4
14	020194	Locknut, Fiber #10-24UNC	4
15	139537	Water Valve, 1/2 NPT	1
16	020836	Elbow, 45° Female 1/2 NPT	1
17	139641	Air Filter Regulator Unit	1
18	020762	Washer, Flat .250 SAE	4
19	020416	Screw, Mach Rd Hd .250-20UNC x .75	4
20	020195	Locknut, Fiber .250-20UNC	4
21	139649	Bushing, 1/2 NPT x 1/4 NPT	1
22	139642	Air Relief Valve, 125psi	1
23	162657	Restricted Nipple, 3/4 NPT x 1/2 NPT	1
24	139640	Muffler	1
25	161117	Coupling	1
26	139643	Air Hose Assy	1
27	139651	Pulley Assy, 2G3V2.65 w/Taper Hub	1
28	139652	Pulley, 2G3V2.65 1108 T-L	1
29	161099	Hub, Taper 1108 -.75 Bore	1
30	167744	V-Belt, 3VX280 (Set of 2)	1
31	167743	V-Belt, 3VX280	2

# Diagram 10 – Kit, Water Tank (174957)

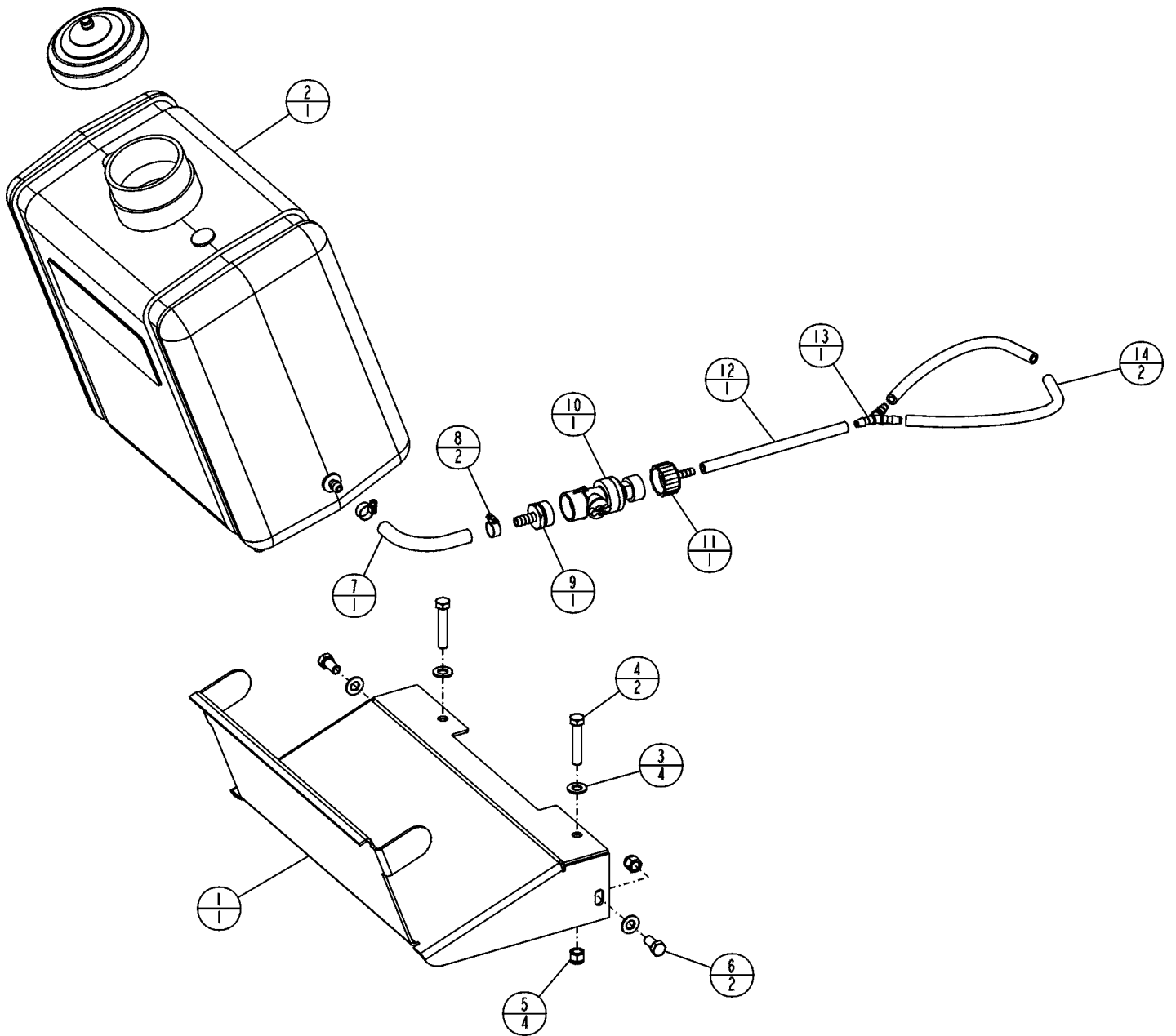

## BILL OF MATERIAL

INDEX	P/N	DESCRIPTION	QTY
1	196035	Bracket, Water Tank	1
2	174648	Water Tank (w/cap), 7 Gallon	1
3	020764	Washer, Flat .375 SAE	4
4	020509	Capscrew, Hex Hd .375-16UNC x 2.00	2
5	020199	Locknut, Fiber .375-16UNC	4
6	020322	Capscrew, Hex Hd .375-16UNC x .75	2
7	139722	Hose, 3/8 ID x 4.4	1
8	020049	Hose Clamp, Worm Drive	2
9	174016	Fitting, Hose Barb 3/8 ID x 3/4 Male	1
10	174741	Kit: Quick Disconnect Garden Hose w/Valve	1
11	196037	Fitting, 3/4 FGH SWV x 1/4 HB Nylon	1
12	187667	Hose, 1/4 ID x 7in	1
13	196038	Fitting, 1/4 Y Nylon LP	1
14	187667	Hose, 1/4 ID x 9in	2

**NOTE:**  
**NOTA:**

### Target Corporate Office

Customer Service..... 800-288-5040  
Corp. Office..... 913-928-1000  
Cust. Service FAX ..... 800-825-0028  
Corp. Office FAX ..... 913-438-7951  
Cust. Service, Int'l. .... 913-928-1300  
Int'l. E-mail ..... rcoats@db-inc.com

### Target Latin America, Mexico, Caribbean, Central and South America

17400 West 119th Street  
Olathe, Kansas 66061

Phone ..... 913-928-1255  
FAX ..... 913-438-7938  
E-mail ..... hleon@db-inc.com

### Target Canada

17400 West 119th Street  
Olathe, Kansas 66061

Customer Service ..... 800-288-5040  
E-mail ..... rbaker@db-inc.com

### Target Hong Kong, China

Diamant Boart Pte Ltd.  
Unit E, 13/F., Infotech Centre,  
21 Hung To Road, Kwun Tong,  
Hong Kong

Phone ..... 852-2516-6602  
FAX ..... 852-2516-6605  
E-mail ..... targethk.netvigator.com

### Target Japan, Korea, Taiwan

1803-36 Oyama-Machi  
Machida-Shi, Tokyo 194-0212

Japan  
Phone ..... 8142-797-0212  
FAX ..... 8142-798-7515  
E-mail ..... fwnh9794@mb.infoweb.ne.jp

### Target Australia, New Zealand/Dembicon Pty. Ltd

29 Kinkaid Avenue  
North Plympton, Adelaide SA 5037  
Australia

Phone ..... 61-83751000  
FAX ..... 61-83710990  
E-mail ..... enquiries@dembicon.com.au  
Internet ..... www.dembicon.com.au

### Target Brazil

#### Pix Do Brasil

Rua José de Oliveira Coutinho  
São Paulo, Brazil CEP 01144-020

Phone ..... 55 11 3611-8383  
FAX ..... 55 11 3619-3022  
E-mail ..... pixbrasil@uol.com.br

### Target Singapore, Thailand, Vietnam, Malaysia, Indonesia

Phone ..... 65-9628-6175  
FAX ..... 65-234-2896  
e-mail ..... reeh@singnet.com.sg

### European Headquarters DB Construction Business Group

Avenue Du Pont De Luttre, 74  
1190 Brussels, Belgium

Phone ..... (32-2) 348-3669  
FAX ..... (32-2) 348-3136  
Internet ..... www.diamant-boart.com

Target Internet ..... [www.targetblue.com](http://www.targetblue.com)



## WARNING



The engine exhaust from this product  
contains chemicals known to the State  
of California to cause cancer, birth  
defects or other reproductive harm.



# TARGET®

Better Products, Better Solutions

Diamant Boart Group